

Online Appendix for “*Industry-University Collaboration and Commercializing Chinese Corporate Innovation*”

David H. Hsu, Po-Hsuan Hsu, Kaiguo Zhou, and Tong Zhou

A. Extended Literature Review

A.1. *The influence of university research: overview*

The literature tends to portray universities as specializing in basic research while depicting corporates as focusing on technology development and commercialization (Jaffe, 1989; Rosenberg and Nelson, 1994; Trajtenberg, Henderson, and Jaffe, 1997). Such specialization in technology development in turn calls for technologies transfers between universities and corporates and across-sector synergies in innovation.¹

The influence of universities on industry R&D and innovation has been studied since Nelson (1986) and Levin et al. (1987): their surveys suggest that university research is perceived as relevant for industry technological development, especially in high-tech industries including computer science, biotechnology, and medical and agricultural science. Jaffe (1989) shows that university research budgets positively influence local firms’ patent outputs in medical technology, electronics, optics, and nuclear technology. Acs, Audretsch, and Feldman (1992, 1994) find a positive relation between universities’ R&D spending and local firms’ innovation activities; moreover, this relation intensifies with geographic proximity. The survey of Cohen, Nelson, and Walsh (2002) also supports the positive influence of public research (conducted in either academia or government labs) on industrial R&D. Narin, Hamilton, and Olivastro (1997) find that references from U.S. patents to U.S.-authored research papers have tripled between the late-1980s and early-to-mid-1990s, confirming the linkages between current public research (conducted in either academia or government labs) and industrial technology. Sorenson and Fleming (2004) and Hsu et al. (2021) pointed out that the forward citations and value of corporate patents are positively associated with their backward citations to basic research. All these discussions collectively support the pivotal role of university research and spillover on industrial technology.

¹ Lacking complementary assets, universities suffer from a low direct commercialization rate of technologies. For example, Hsu et al. (2021) document that only 16% of patent value is realized through university licensing. Industry-university collaboration (IUC) is an essential mechanism to solve such dilemma (Lee, 1996; Hanel and St-Pierre; 2006; Bruneel, D’Este, and Salter, 2010; Perkmann, King, and Pavelin, 2011).

There are also studies that suggest that the impact of university spillover on industrial technology is smaller than that of between-firm spillovers (e.g., Klevorick et al., 1995). Prior studies have shown the importance of between-firm technology collaboration and cross-learning (Powell, Koput, and Smith-Doerr, 1996; Cassiman and Veugelers, 2002), which lowers the R&D costs and increases the quantity and quality of firms' innovation outputs (Belderbos, Carree, and Lokshin, 2004; Scandura, 2016). The collaboration between universities and corporates is an important form of technology partnership but whether and how such collaboration enhances firms' innovation performance remains under debate (e.g., Mowery et al., 2004) and still needs further empirical analysis. Some prior studies have also pointed out the barriers and obstacles in such collaborations (Siegel, Waldman, and Link, 2003; Bruneel, D'Este, and Salter, 2010).

From universities' perspective, there is an extensive set of prior studies focusing on universities' missions and incentives on IUC (such as Link and Siegel, 2005; Siegel and Wright, 2015), which has been considered as universities' "third mission" other than research and education (Perkmann et al., 2013).² Successful IUC will bring compensation and visibility to university scientists (Owen-Smith and Powell, 2001; D'Este and Perkmann, 2011; van Rijnssoever, Hessels, and Vandeberg, 2008); thus, they will have incentives to work with companies which can offer complementary resources. In particular, science and engineering faculty seek corporate partners for resources relevant to their research activities and the opportunities to learn about potential markets (Lee, 2000; D'Este and Perkmann, 2011). In addition, faculty members' IUC experience may even help students (Lin and Bozeman, 2006). Some studies suggest a positive relation between faculty members' research output and engagement in IUC (e.g., Blumenthal et al., 1996), while some find no association (e.g., Gulbrandsen and Smeby, 2005).

The positive effect of IUC on corporate innovation has been well-documented in the literature (Gittelman and Kogut, 2003; Walsh, Lee, and Nagaoka, 2016; Scandura, 2016). We note that prior studies on the effects of IUC on corporate innovation are mainly based on survey data in developed countries.³ Collaborating with universities is particularly relevant for Chinese firms that tend to have shorter histories and weaker R&D capabilities. In addition, universities serve as hubs of social networks in Chinese

² Nevertheless, Huang and Murray (2009) show that increased academic patenting may have a negative impact on knowledge diffusion. In addition, Hsu, Hsu, and Zhao (2021) document that only a small fraction of patent value is realized through university licensing in the U.S.

³ An incomplete list of prior studies includes Azagra-Caro et al. (2006), D'Este and Patel (2007), Motohashi and Yun (2007), Segarra-Blasco and Arauzo-Carod (2008), Perkmann and Walsh (2009), Bruneel, D'Este, and Salter (2010), Giuliani et al. (2010), D'Este and Perkmann (2011), Motohashi and Muramatsu (2012), Hewitt-Dundas (2013), Scandura (2016), among others. Using an IUC survey among U.K. firms, Scandura (2016) find that firms participating at IUC projects are associated with significant increases in R&D investment.

society (Obukhova, Wang, and Li, 2012) and may thus enable collaborating firms to access broader knowledge and technology sources. All these make it important for us to examine the effects of IUC in China.

There is an increasing trend for Chinese firms to engage in IUC (Motohashi and Yun, 2007), and local surveys suggest that over 10% of firms engage in research collaboration with universities. At the same time, these surveys also highlight firms' challenges in engaging with universities. In a survey of 950 Beijing firms in 1996, 18% of high-tech firms consider research institutes and universities as important research input and 19% of them collaborate with research institutes and universities in their new product development (Guan, Yam, and Mok, 2005). In this survey, "Lack of efficient communication channel" was ranked as the top barrier for the acquisition of research results from R&D institutes and universities. In fact, the item was ranked as the top three barriers by 57% of high-tech firms. In another survey of 703 private enterprises in Shanghai in 2006, 14% of firms have conducted joint research with universities (Wu and Zhou, 2012). In this survey, common obstacles to collaboration with universities include "different perception of technology maturity and timeliness" (23%), "university R&D lagging behind market trends" (23%), "university R&D too expensive" (17%), and "lack of intermediary for information exchange" (14%).

Several studies support a positive relation between Chinese firms' R&D investment and their IUC activities. Motohashi and Yun (2007) use the NBS survey and find that firms with higher internal R&D are also more likely to outsource R&D to universities, research institutes, and other firms. Zhou (2012) shows that firms with higher R&D investment are more likely to engage in research partnership with universities rather than other research institutes or peer firms. In addition, Brehm and Lundin (2012) find a complementary relationship between capabilities of acquiring external knowledge and exploiting such knowledge among Chinese firms.

However, Arora, Belenzon, and Pataconi (2018) have documented a consistent decline in corporates' investment in scientific research since the 1980s, which is especially true when their knowledge creation results in spillovers to rivals (Arora, Belenzon, and Sheer, 2020). A similar pattern is also observed in China. Motohashi and Yun (2007) find an increasing trend in Chinese manufacturing firms' outsourcing R&D to universities and public research institutes (PRIs) for the 1996-2002 period. The declining efforts in corporate scientific research due to intensified technology competition and declining appropriability of scientific research implies an increasingly important role of IUC in corporate innovation.

The effect of IUC varies by industries. Pavitt (1984) analyzes the technological changes of 2,200 innovations in the U.K. since 1945 and categorize them into four

categories: science-based firms, supplier-dominated firms, and scale-intensive firms. The Yale Survey of 650 industry experts reports that university research is perceived as relevant for industry technological development, especially in agriculture, drug, engineering and scientific instruments, and semiconductors (Nelson, 1986; Klevorick et al., 1995). Mansfield's (1991 and 1998) survey of managers and technicians in 76 U.S. firms suggests that academic research is particularly fundamental to drugs and medical products, instruments, and information processing industries. Cohen, Nelson, and Walsh (2002) find clear differences in the impacts of public research on corporate innovation across industries using a survey of 1,478 R&D labs.

Such industry heterogeneity also occurs to China: Motohashi and Yun (2007) find that more than 30% of Chinese firms' collaborations with research institutes and universities occur in drugs and petrochemicals industries that are more science-dependent. Also, Brehm and Lundin (2012) show that universities' impact on corporate technology commercialization is contingent on industries' dependence on external knowledge.

In addition, the effect of IUC also varies by locality in China: Hong (2008) argues that, due to the uneven distribution of economic development and institutional environments, firms in underdeveloped regions are subject to great disadvantages in university spillovers. Hong and Su (2019) find that Chinese firms' collaborations with universities are closely related to geographic distance; and geographic distance also moderates other factors including social proximity, institutional proximity, and university reputation.

A.2. The influence of university research: corporate technology commercialization

Previous studies, such as Eisenhardt and Schoonhoven (1990), Nevens, Summe, and Uttal (1990), Brown, Berry, and Goel (1991), George, Zahra, and Wood (2002), Eesley, Hsu, and Roberts (2014), among many others, have identified that the composition of research teams, technological capacity, market position, management techniques, and corporate culture are factors that influence the effectiveness of a firm's technology commercialization. This study adds to this stream of the literature by showing IUC as an additional driving force, which complements the finding of Mansfield (1991).

The effect of IUC on technology commercialization is important yet lacking large-scale empirical analysis in the literature for the following reasons:⁴ first, prior IUC research tends to focus on the benefits to universities rather than corporates (e.g., Link

⁴ Some of the earliest work in this domain include Mansfield's (1991) survey of 76 firms suggesting that prior academic research facilitates about 10 percent of new products and processes. In addition, using a survey among 517 European firms, Kaufmann and Tödtling (2001) find that firms' forming partnership with universities is related to a higher probability of product inventions.

and Siegel, 2005; Siegel and Wright, 2015). Second, due to the lack of firm-level technology commercialization data, empirical studies for corporate innovation often rely on firms' patents and inventions instead of their revenue from these innovations. In addition, those with firm-level technology commercialization data are based on small-scale survey data in developed countries.⁵ Third, universities lack complementary assets and related experience for commercialization. For example, Hsu et al. (2021) document that only 16% of patent value is realized through university licensing.

As shown in Figure OA.1 Panels A and C, the number of Chinese IUC patents and papers per year increases dramatically from 1994 to 2016, reflecting both universities' and corporates' increasing efforts in collaborative innovation. In comparison, the number of IUC patents filed in the U.S. from 1994 to 2016 is quite stable, as shown in Panel A.⁶ In addition, as illustrated in Figure OA.1 Panel B, the ratio of IUC patents as compared to all university patents (in the black dotted line) in China fluctuates around 4% — it increases dramatically from 1999 to 2002 but declines gradually thereafter.⁷ A similar pattern appears in Panel C when we examine IUC papers to university papers (in the black dotted line). In contrast, the ratio of IUC patents relative to all university patents (in the grey dotted line) in the U.S. remains at 9% in Panel B — this comparison probably reflects the fact that U.S. universities are better at technology transfer. When we examine the ratio of IUC patents over corporate patents, we find that this ratio is higher in China (the black dashed line) compared to the same ratio in the U.S. (the grey dashed line) in Panel B, suggesting that IUC may play an important role in Chinese firms' innovation development. This warrants further investigation in future research.

⁵ Prior studies on firm-level technology commercialization are mainly based on small-scale survey data in developed countries. For example, Kaufmann and Tödting (2001) use a survey of 517 firms in European regions; Becker and Dietz (2004) consider a manufacturing industry survey of about 2,900 firms in Germany; Belderbos, Carree, and Lokshin (2004) use community innovation surveys of 2,056 in the Netherlands; Motohashi (2005) studies an industry survey of 724 firms in Japan; Berchicci (2013) consider a survey on about 2,900 Italian manufacturing firms between 1998 and 2004; Maietta (2015) examines a manufacturing industry survey of 1,744 firms in Italy; Walsh, Lee, and Nagaoka (2016) studies a survey of about 1,900 inventors in the U.S.

⁶ For the US data, we use the PatentsView database and examine the assignee codes of all co-assignees of a patent to identify if it is assigned to a company and a university or research organization.

⁷ The rise and fall of the ratios of IUC patents over corporate patents before and after 2003 are probably driven by a series of policies that affected universities' incentives in collaboration with industry. Since the economic reforms of the 1980s, the central and local governments encouraged universities to run enterprises to gain additional funding. As universities spin off their laboratories and research centers as firms (still affiliated with universities), it is likely that the patents invented in these business units are co-assigned to both the university-run firms and the universities. These spin-offs are dropped from our sample because we exclude firms that have joint patenting with universities in their first five years. However, the central government later clarified that university-run firms should promote technology transfer and incubate high-tech enterprises. Starting from late 2002, universities gradually divested their shares in firms that are regarded as "non-scientific" or "non-technological." Since then, patents invented in a large number of formerly university-run enterprises are not assigned to universities.

Figure OA.1: Time Series of IUC Patents and Papers in China and the U.S.

In Panel A, the black and grey lines represent the numbers of corporate patents applied (and eventually granted) in year t in China and the U.S., respectively. In Panel B, the black and grey dashed lines represent the ratios of industry-university collaborative patents applied (and eventually granted) in year t over corporate patents applied (and eventually granted) in year t in China and the U.S., respectively. The black and grey dotted lines represent the ratios of industry-university collaborative patents applied (and eventually granted) in year t over university patents applied (and eventually granted) in year t in China and the U.S., respectively. In Panel C, the solid line represents the number of IUC papers published in year t in China; the dashed black and grey lines represent the ratio of IUC papers divided by corporate papers and university papers, respectively. A patent is defined as industry-university collaborative if it is assigned to both a university and a corporate. A paper is defined as industry-university collaborative if it is affiliated with both a university and a corporate. Sample period: 1994-2016.

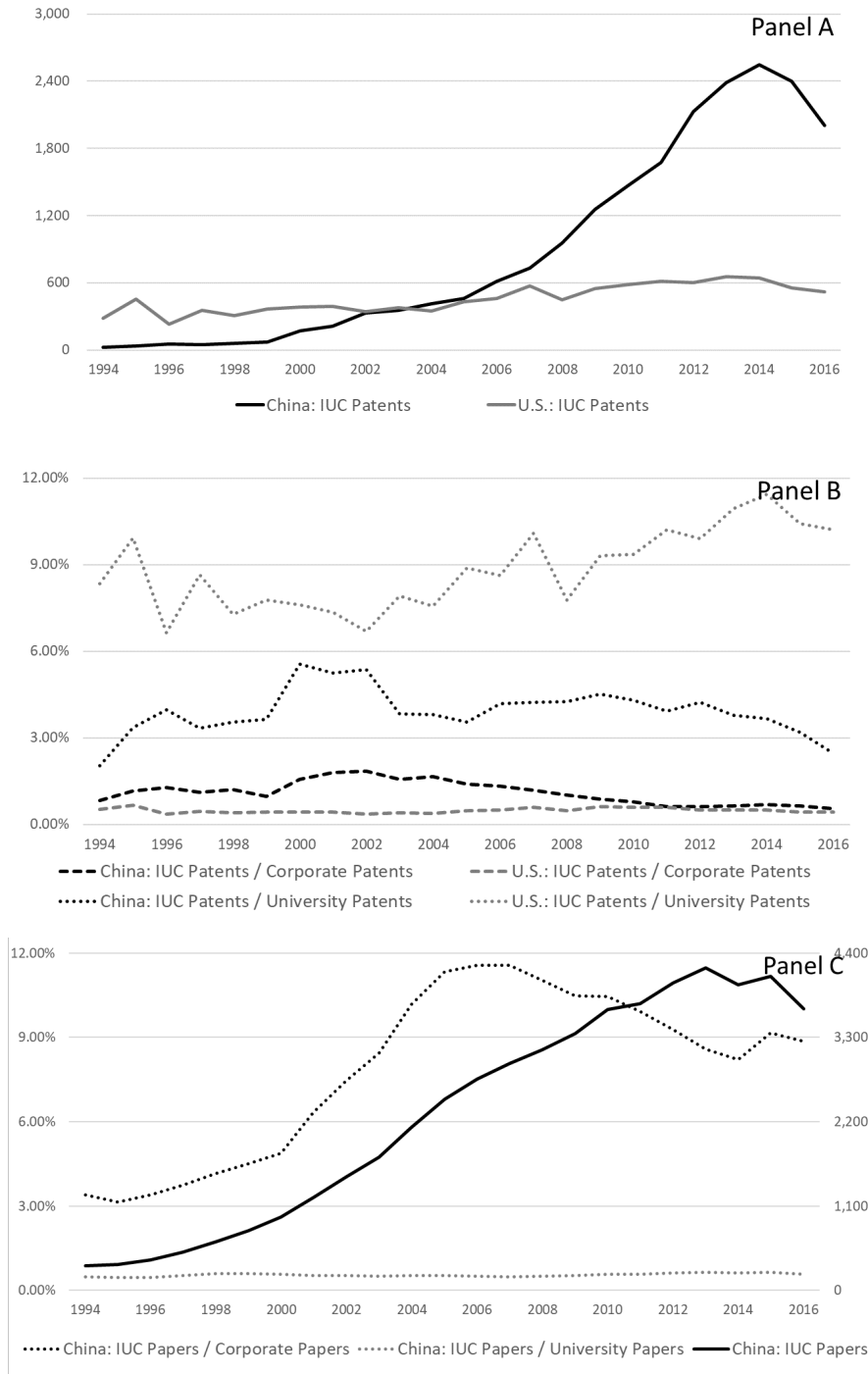

A.3. The influence of university research: micro foundations

Our literature review suggests two micro foundations for IUC to enhance corporate innovation and technology commercialization: knowledge acquisition and talent recruiting (Prager and Omenn, 1980; Mowery and Ziedonis, 2014). As argued by Prager and Omenn (1980), firms could benefit from IUC for “*additional sources of ideas, knowledge, and technology on which to base potential new products and processes.*” The survey of R&D managers by Cohen, Nelson, and Walsh (2002) points out that firms indeed learn from universities through published papers and reports, public conferences and meetings, informal information exchange, and consulting. The literature on between-firm collaboration has documented that collaboration facilitates cross-learning (Powell, Koput, and Smith-Doerr, 1996; Cassiman and Veugelers, 2002), which is likely effective in IUC because learning from university research lowers the R&D costs of firms (Belderbos, Carree, and Lokshin, 2004; Scandura, 2016).

Human capital from universities is another important aspect. Prager and Omenn (1980) argue that firms could benefit from IUC for “*source of potential research employees sympathetic to industry needs.*” As IUC creates opportunities for university researchers and corporate managers and R&D staff to interact, it could increase inventor flows into industry (Lee, 1996). As patent inventors from universities can bring in new knowledge that are complementary to research experience of incumbent corporate R&D staff, such inflow is conducive to corporate innovation (Østergaard, Timmermans, and Kristinsson, 2011; Qian et al., 2013; Che and Zhang, 2018). In addition, there may exist synergies from the integration of basic research and commercial development that may enhance innovation efficiency. This is supported by the individual- or patent-level data: Gittelman and Kogut (2003) show that scientists who are capable in both publishing at academic journals and patenting can produce more influential patents, and Walsh, Lee, and Nagaoka (2016) find that U.S. patents resulting from collaboration with universities are associated with higher technical significance. Recent studies, such as Seo and Somaya (2022) and Piezunka and Grohsjean (2023), examine inventor mobility following inter-firm collaboration.

B. Categorization of Product-Oriented Patents

In the Chinese setting, a process-oriented patent application always specifies “process” words (“方法,” “工艺,” or “过程” in Chinese).⁸ As an illustration, compare the following patent examples #1 and #2. In the patent application document of Patent Example #1, its title ends with “方法.” When we look into its abstract, it claims that this innovation is expected to simplify and reduce the costs of a manufacturing process of recombinant enterokinase. In the patent application document of patent example #2, its title does not have the “process” feature. It is confirmed as a product-oriented patent, since its abstract claims that this patent invents a new electronic component.

Some product-oriented patents invent new products with new processes. In the patent application documents of patent examples #3 and #4 below, even though these patents propose new processes, their titles and abstracts imply that their main focus is to invent new products (i.e., a coffee machine and an electrical equipment). Thus, they are categorized as product-oriented patents. Following the rule of thumb, the title of patent example #3 does not end with words of “processes.” Even though the title of patent example #4 ends with words of “processes,” it has a word of “及其” (translated into English as “and its”), indicating that the new product is accompanied by a new process.

⁸ Liu, Sojli, and Tham (2020) and Ganglmair, Robinson, and Seeligson (2022) develop algorithms to exploit the English text of patent titles and claims to assign U.S. and international patents into product- and process-oriented patents.

Patent Example #1: Process-Oriented Patents

(19)中华人民共和国国家知识产权局



(12)发明专利申请



(10)申请公布号 CN 108265042 A

(43)申请公布日 2018.07.10

(21)申请号 201611258115.6

(22)申请日 2016.12.30

(71)申请人 江苏万邦生化医药集团有限责任公司

地址 221004 江苏省徐州市金山桥经济开发
区杨山路6号

申请人 上海复星医药(集团)股份有限公司

(72)发明人 文良柱 赵珊珊 胡婷 刘慧萍

(51)Int.Cl.

C12N 9/64(2006.01)

C12N 15/57(2006.01)

C12N 15/70(2006.01)

权利要求书2页 说明书8页
序列表6页 附图4页

(54)发明名称

一种重组肠激酶的制备方法

(57)摘要

本发明提供了一种制备重组肠激酶的方法,该方法包括:(1)重组表达融合蛋白,所述融合蛋白序列从N端到C端依次包括:100-250个氨基酸序列、肠激酶序列;(2)切除融合蛋白N端所述的100-250个氨基酸序列获得重组肠激酶,所述重组肠激酶的氨基酸序列为Seq ID No.1,核苷酸序列为Seq ID No.4。本发明所述方法制备工艺简单、成本低,无需经过变性和复性,并且纯化步骤简单方便制备的重组肠激酶活性高。

Patent Example #2: Product-Oriented Patents

(19)中华人民共和国国家知识产权局



(12)发明专利申请



(10)申请公布号 CN 107204534 A

(43)申请公布日 2017.09.26

(21)申请号 201610151963.0

(22)申请日 2016.03.17

(71)申请人 富士康(昆山)电脑接插件有限公司

地址 215316 江苏省苏州市昆山市玉山镇
北门路999号

申请人 鸿腾精密科技股份有限公司
华硕电脑股份有限公司

(72)发明人 房军 印小虎 高禾春 萧清华

池怡莹 李侑澄

(51)Int.Cl.

H01R 13/502(2006.01)

H01R 13/717(2006.01)

H01R 13/73(2006.01)

H01R 12/73(2011.01)

权利要求书1页 说明书4页 附图5页

(54)发明名称

卡缘连接器及其组件

(57)摘要

一种卡缘连接器,包括纵长的绝缘本体、固持于所述绝缘本体内的若干导电端子及设于所述绝缘本体的金属元件。所述绝缘本体设有沿纵长方向延伸的两侧壁、位于纵长末端并连接所述两侧壁的两端壁以及位于所述两侧壁及两端壁间的中央插槽,所述导电端子沿纵长方向设置于所述两侧壁上并凸伸入所述中央插槽内。所述绝缘本体的侧壁设有自其外侧面向内凹陷的凹槽,所述卡缘连接器还包括收容于所述凹槽内的导光板。所述金属元件包括位于所述凹槽处并遮蔽所述导光板的遮蔽部及自所述遮蔽部的一侧向内弯折延伸的漏光部。所述漏光部设有若干可使所述导光板露出的镂空槽。可以增强产品承重性能,配合产品可承受较重显卡。

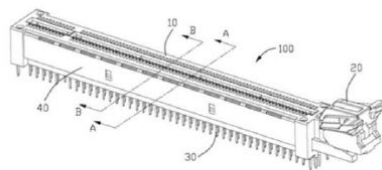

33 A

Patent Example #3: Product-Oriented Patents

(19)中华人民共和国国家知识产权局



(12)发明专利申请



(10)申请公布号 CN 111436829 A

(43)申请公布日 2020.07.24

(21)申请号 201910039944.2

(22)申请日 2019.01.16

(71)申请人 珠海格力电器股份有限公司
地址 519070 广东省珠海市香洲区前山金鸡西路789号

(72)发明人 周幸 陈翀

(74)专利代理机构 北京煦润律师事务所 11522
代理人 梁永芳

(51)Int.Cl.
A47J 31/42(2006.01)
A47J 31/44(2006.01)

权利要求书2页 说明书7页 附图4页

(54)发明名称

咖啡的制作方法、制作装置和咖啡机

(57)摘要

本申请提出一种咖啡的制作方法、制作装置和咖啡机,其中制作装置,包括:采集模块,用于收集用户的个性化数据;获取模块,用于确定用户选中的咖啡豆;方案模块,用于根据咖啡豆的咖啡豆数据和参考数据采用预设算法确定咖啡的制作方案;制作模块,用于根据制作方案将咖啡豆制作成咖啡;其中,咖啡豆数据包括咖啡豆品种,参考数据包括个性化数据。从而保证了用咖啡豆制作的咖啡满足用户的口味,提高了用户的体验。

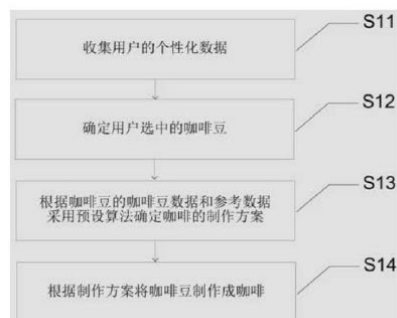

Patent Example #4: Product-Oriented Patents

(19) 中华人民共和国国家知识产权局



(12) 发明专利申请

(10) 申请公布号 CN 112886302 A

(43) 申请公布日 2021.06.01

(21) 申请号 202110042416.X

(22) 申请日 2021.01.13

(71) 申请人 富士康(昆山)电脑接插件有限公司

地址 215316 江苏省苏州市昆山市玉山镇
北门路999号

申请人 鸿腾精密科技股份有限公司

(72) 发明人 王新利 李志科 卞道振

(51) Int. Cl.

H01R 13/03 (2006.01)

H01R 43/16 (2006.01)

权利要求书1页 说明书4页 附图6页

(54) 发明名称

导电端子及其制造方法

(57) 摘要

一种导电端子及其制造方法,所述导电端子由铜材电镀及冲压而形成,其表面具有镍层;所述导电端子包括筒状区及位于所述筒状区后方的夹线区,所述筒状区具有相对的内侧及外侧且自前向后依次为导引区、接触区及定位区,所述接触区的内侧设有接触点,所述导引区与接触区之间仅局部相连。所述导引区的外侧表面的镍层厚度为小于所述导电端子其他部位的镍层厚度。本发明导电端子采用分段电镀以及倾斜电镀的电镀方式,使得导电端子导引区的镍层厚度小于其他部分的镍层厚度,如此,平面结构的铜片弯折形成导电端子时,有效改善导引区外侧表面龟裂的现象。

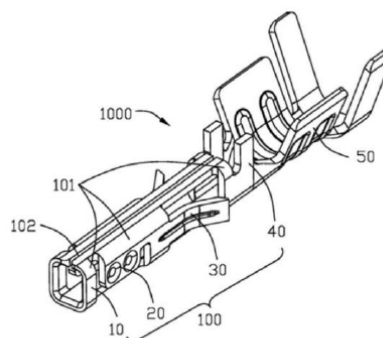

C. Searching Manual in CNKI

We go through the lists of NBS firms and universities. For each firm or university, we take the following steps to collect their paper publication information.

Step 1: Go onto the CNKI platform

<https://www.cnki.net/>

Step 2: Search

Select the category of academic papers (“学术期刊” in Chinese). Select the searching condition as paper affiliation (“作者单位” in Chinese). Input the name of a firm or university and click search.

The screenshot displays the CNKI website interface. At the top, there is a navigation bar with options like '旧版入口', '手机版', 'ENGLISH', '充值', '会员', '帮助', '个人/机构馆', '我的CNKI', '欢迎', and '登录'. Below this is a search bar with '作者单位' selected and a search button. A secondary navigation bar includes '文献检索', '知识元检索', and '引文检索'. The main content area is organized into three columns: '行业知识服务与知识管理平台', '研究学习平台', and '专题知识库'. Each column lists various services and categories, such as '科技創新服務', '农业牧渔、卫生、科学研究', '建筑、能源、冶炼、交通运输', '制造、信息技术、贸易', '党政、社团、国防、法律、金融', '教育、公共文化、社会服务', '知网研学习平台', '大数据研究平台', '协同研究平台', '在线教学服务平台', '个人查重服务', '作者服务', '学位论文领取稿酬通告', '心可书馆', '出版平台', '科研统计与期刊评价', '环保治理', '金融', and '文化知识'.

Step 3: Data collection and cleaning

Crawl the paper information on each page of the search results. We manually check and do not find any case where the search engine returns a paper that is not affiliated with our firms and universities.

The screenshot shows a search result on the CNKI (China National Knowledge Infrastructure) platform. The search criteria are set to 'Author: Tsinghua University' and 'Academic Journal'. The results list 11 papers. The selected paper is '“双碳”目标下用能权交易制度的法律检视' by Chen Yingda, published in the Northwest University Journal (Philosophy and Social Science Edition) in 2023. The paper is indexed by CSDDB and CSSCI. The abstract discusses the legal framework for energy rights trading under the 'dual carbon' target, highlighting the need for clear property rights and market mechanisms. The paper is available in HTML, CAJ, and PDF formats.

篇名	作者	刊名	发表时间	被引	下载	操作
1 “双碳”目标下用能权交易制度的法律检视	陈英达	西北民族大学学报(哲学社会科学版)	2023-01-14		↓	📄 ⭐ 🔄
2 博物馆的空间与记忆叙事对文化认同的建构与形塑——以中国太极拳博物馆为例	韩晓明; 乔凤杰; 杨慧	西北民族大学学报(哲学社会科学版)	2023-01-14		↓	📄 ⭐ 🔄
3 产业链与元宇宙权: 新变局中的定义和重塑	林天强	闽江学刊	2023-01-14		↓	📄 ⭐ 🔄
4 从现代化的规范含义理解“中国式现代化”	任剑涛	江汉论坛	2023-01-14		↓	📄 ⭐ 🔄
5 基于OBE理念的幼儿园足球运动发展目标设计	李守江; 郝文鑫; 郑小雯; 张悦虹; 陈龙龙	陕西学前师范学院学报	2023-01-14		↓	📄 ⭐ 🔄
6 当代政治哲学视域下的马克思主义共同体思想探析	暴扩明; 宋金	哈尔滨工业大学学报(社会科学版)	2023-01-13 15:38		↓	📄 ⭐ 🔄
7 基于信息检索与数据挖掘的食品安全舆情监测与引导研究——以大型农贸市场食品安全微博舆情实证研究为例	徐博	食品科学	2023-01-13 14:34		↓	📄 ⭐ 🔄
8 单克隆抗体制备过程中抗体检测方法释疑	梁姝函	生物学教学	2023-01-13 14:34		↓	📄 ⭐ 🔄
9 考虑初始风速与机端故障稳态电压跌落程度的直驱风机故障响应特性分类及其判别方法研究	李东晟; 沈沉; 吴林林; 程雪琦; 杨艳晨	中国电机工程学报	2023-01-13 12:54		↓	📄 ⭐ 🔄
10 黄河下游典型滩区社会经济-防洪安全-生态环境耦合协调分析	李想; 赵连军; 李东阳; 韩沙沙; 牛杰杰	中国农村水利水电	2023-01-13 12:16		↓	📄 ⭐ 🔄
11 一种线性时间复杂度的高效路由保护方法	耿海军; 张琪栋; 尹雷	计算机应用研究	2023-01-13 09:34		↓	📄 ⭐ 🔄

西北民族大学学报(哲学社会科学版) · 2023(01) [北大核心] [CSSCI]

“双碳”目标下用能权交易制度的法律检视

陈英达
清华大学法学院

摘要: 用能权交易制度是我国能源要素市场化改革的重要制度安排。目前,我国用能权交易市场尚处于探索阶段,存在着用能权的权利属性界定不明与初始分配规则不一,进而导致用能权交易制度开展的理论基础不彰与整体建构失调;用能权交易市场呈现出市场活跃度低、与其他环境权益市场交叉等问题。由此,需完善用能权一级市场与二级市场的法律规范建设,为全面推进用能权交易市场提供制度保障;应以用能权的权利客体(能量)为逻辑基点展开思考,确信用能权的准物权属性;在明确其权利属性的前提下,应实现用能权初始分配模式科学化发展;应探索用能权交易主体的扩围,开拓多种交易形式,不断盘活市场动力;应确保用能权与碳排放权交易市场的协同共建,在解决重复计算的基础上不断探索两权市场的制度合力建设,共同作用于“双碳”目标的实现。

关键词: 用能权交易; 用能指标; 权利属性; 初始分配; 环境权益市场; “双碳”目标

基金资助: 国家自然科学基金一般项目“国际海底区域资源用益制度的法经济学研究”(项目编号:198FX214);清华大学自主科研计划文科专项“国际海底区域资源开发用益的法律路径研究”(项目编号:2019THZWLJ03);

DOI: 10.14084/j.cnki.cn62-1185/c.2023.01.011

编辑: 社会科学 I 辑/社会科学 II 辑

专题: 行政法及地方法制

分类号: D922.6

手机阅读 | HTML阅读 | CAJ下载 | PDF下载

页码: 73-81 页数: 9
大小: 289K

D. Other Innovation Measures

In addition to counts and forward citations¹, we further construct three measures for the quality of product-oriented patents. Following Trajtenberg, Henderson, and Jaffe (1997) and Fleming and Sorenson (2004), we construct *Product-Oriented PatBasic* as the ratio of backward citations (i.e., references) to non-patent prior art (such as academic papers) divided by total backward citations of product-oriented patents that are filed by the focal firm in year $t + 1$.² A higher value of *Product-Oriented PatBasic* suggests that a firm's product-oriented patents cite academic papers more often and are thus more directly built on basic research.

Product-Oriented PatExplore denotes the ratio of exploratory product-oriented patents over the number of product-oriented patents filed by the focal firm in year $t + 1$. A patent is defined as an exploratory patent if its applicable primary International Patent Classification (IPC) codes are different from those of patents filed by the same firm in years $t - 4$ to t . *Product-Oriented PatExplore* measures how different a firm's future innovation outputs are from its historical innovation outputs in term of technology fields. As shown in Table 1, conditional on firm-year observations with a least one product-oriented patent, the averages of *Product-Oriented PatBasic* and *Product-Oriented PatExplore* are 0.26 and 0.86, respectively.

Following Lerner (1995), we construct *Product-Oriented TechBreadth* as the average number of unique primary IPC codes per product-oriented patent filed by the focal firm in year $t + 1$. *Product-Oriented TechBreadth* therefore measures how a patent's technology can be generally applied *across* technology fields. Table 1 shows that, conditional on firm-year observations with a least one product-oriented patent, the mean of *Product-Oriented TechBreadth* is 1.19.

We estimate Equation (1) by using *Product-Oriented PatBasic*, *Product-Oriented*

¹ For citations, we follow previous studies such as Liegsalz and Wagner (2013), Boeing, Mueller, and Sandner (2016), Fisch, Block, and Sandner (2016), Fisch, Sandner, and Regner (2017), Boeing and Mueller (2019), Shubbak (2019), Lin, Wu, and Wu (2021), and de Rassenfosse and Raiteri (2022) and use the Item 56 references (“对比文件” in Chinese) listed on the front page of each patent issuance document. Since they are selected by patent examiners as key to judge on a patent's “novelty” and “inventiveness,” they are objective and less subject to manipulation or selection bias in applicants' citations. Moreover, other commonly used databases, such as Google Patents and PATSTAT, only record Item 56 references as backward citations (Shi et al., 2022).

² Cassiman, Veugelers, and Zuniga (2008) show that firms' publication records and references to academic research are positively associated with firms' patent quality.

PatExplore, and *Product-Oriented TechBreadth* as the explanatory variable. The results are reported in Online Appendix Table OA.4. We find that IUC experience is associated with significantly higher reliance on basic research in Panel A, significantly higher exploration in Panel B, and significantly higher breadth in Panel C. These results are intuitive: consistent with the common belief that university-generated technologies can be applied to broader applications, which may lead to more commercialization opportunities for firms with IUC experience. As patents that are based on basic research tend to have broader applications (Trajtenberg, Henderson, and Jaffe, 1997), we expect firms with IUC experience to produce more exploratory corporate innovation (i.e., different from the firm's existing technology expertise). Similarly, the strengthened base on basic science could also be reflected in firms' technology breadth (i.e., corporate patents could be more general across and within technology classes).

E. Event Analyses

In this section, we discuss the following two sets of staggered difference-in-differences (DiD) analyses that help us to assess the extent to which our empirical results are driven primarily by omitted variables. Following Baker, Larcker, and Wang (2022), we also implement stacked DiD (untabulated) and obtain qualitatively consistent results.

E.1 Promotion of national university science parks

Our first test exploits the promotion of university science parks (USPs) from the local level to the national level. USPs in China are first initiated by local governments associated with universities and industrial practitioners to enhance regional technology transfer and economic development (Tan, 2006). When a local-level USP performs well in specific criteria (mainly IUC performance),¹¹ it can be promoted by the central government to be a national NSP and then receives further resources.¹² We collect all upgrade events and list them in Table OA.13 in the Online Appendix.

To perform the DiD analysis, we define our sample as firm-year observations in cities with at least one university science park. We regress firms' IUC and technology commercialization measures on *National University Science Park (Post)* and other control variables and fixed effects,¹³ and present the results in Table OA.9 in the Online Appendix. *National University Science Park (Post)* equals one for all firms in this city if a city's local-level university science parks have been promoted to the national-level; otherwise it equals zero.

As the dependent variables in Panel A, *Patent-Based IUC (Paper-Based IUC)* denotes the natural logarithm of one plus the number of patents applied by (papers published by) both a university and the focal firm in year t . As the dependent variables in Panel B, *New Product Sales* denotes the natural logarithm of one plus the output value of new products (in million RMB) in year t ; *Product-Oriented PatCount* denotes

¹¹ It is widely accepted that the most important metrics include the quantity and quality of IUC outputs, technology transfers of associated universities and institutes, and innovation performance of associated firms. Such criteria are codified in the *Guiding opinions on the evaluation of national university science parks* issued by the Chinese Ministry of Science and Technology and the Ministry of Education in 2010. Although every USP has a strong incentive to apply for an upgrade, the central government conducts the assessment every year or two; in each round of assessment, only about ten USPs are upgraded. See: https://www.most.gov.cn/xxgk/xinxifenlei/fdzdgknr/fgzc/gfxwj/gfxwj2010before/201103/t20110302_85052.html and http://www.moe.gov.cn/jyb_xxgk/gk_gbgg/moe_0/moe_7/moe_16/tnull_164.html.

¹² Online Appendix Table OA.13 provides the list of local USPs and national USPs. As suggested by the national university science park "tenth five-year plan" development plan issued by the Ministry of Education in 2001, compared with their local-level counterparts, national USPs receive more support to IUC activities (tax reduction and land supply). See: https://www.most.gov.cn/xxgk/xinxifenlei/fdzdgknr/fgzc/gfxwj/gfxwj2010before/201103/t20110302_85052.html and http://www.moe.gov.cn/jyb_xxgk/gk_gbgg/moe_0/moe_7/moe_16/tnull_164.html.

¹³ We control for firm characteristics such as *Total Assets* (in billion RMB), *Age*, *Cash Ratio*, *Capital Expenditure Intensity*, *Profitability Ratio*, *Sales Growth*, *Export Ratio*, *Leverage Ratio*, *Labor Ratio*, *Wage per Employee*, *Subsidy Ratio*, as well as USP time trends, firm fixed effects, and year fixed effects.

the natural logarithm of one plus the number of product-oriented patents solely applied by the focal firm.

We find that both local firms' IUC activities and technology commercialization increase significantly after local USPs being promoted to national USPs. We do not find more active IUC or higher technology commercialization among treated firms before the promotion. This finding helps mitigate the concern of local governments' policies or specific industry trends being an omitted variable because, if local governments' policies or the growth opportunity of specific industries are driving the positive IUC experience-technology commercialization relation, we should have observed increases in IUC activities or technology commercialization before the events (as firms can change their activities/improve performance before the occurrence year of upgrading and establishment).

E.2 Establishment of university sub-campuses

Our second DiD test exploits the establishment of university sub-campuses in *neighboring* provinces (within a 100km distance).¹⁴ On the one hand, the establishment of university (sub-)campuses creates arguably exogenous benefits for firms with IUC experience in neighboring provinces because these firms possess know-hows about IUC and connections to universities. On the other hand, such an event does not affect other policies and institutional environments these firms encounter. Table OA.14 in the Online Appendix provides the list of university sub-campuses.

To perform the DiD analysis, we exclude firms from the sample if they are in cities that have at least one nearby university campus before the start of our sample period or that have at least one university campus by the end of our sample period. We regress firms' IUC and technology commercialization measures on *University Sub-Campus (Post)* and other control variables and fixed effects,¹⁵ and present the results in Table OA.10 in the Online Appendix. *University Sub-Campus (Post)* equals one for all firms in cities that have experienced the establishment of a university campus within a 100km distance but in another province; otherwise it equals zero.

As the dependent variables in Panel A, *Patent-Based IUC (Paper-Based IUC)* denotes the natural logarithm of one plus the number of patents applied by (papers

¹⁴ Online Appendix Table OA.14 Panel B provides the complete list of university sub-campuses, while Panel A presents a selected list of cities that establish their first university campuses during the sample period; only these events are eligible to enter our DiD sample. Previous studies have documented that firms' innovation benefit from the spillover effects of nearby universities (Jaffe, 1989b; Lehmann and Menter, 2016; Qiu, Liu, and Gao, 2017). Firms in a city that have a university campus are excluded from the treated and control groups.

¹⁵ We control for firm characteristics such as *Total Assets* (in billion RMB), *Age*, *Cash Ratio*, *Capital Expenditure Intensity*, *Profitability Ratio*, *Sales Growth*, *Export Ratio*, *Leverage Ratio*, *Labor Ratio*, *Wage per Employee*, *Subsidy Ratio*, as well as firm fixed effects. As suggested by one anonymous reviewer, we also control for province-year fixed effects to rule out time-varying local economic conditions.

published by) both a university and the focal firm in year t . As the dependent variables in Panel B, *New Product Sales* denotes the natural logarithm of one plus the output value of new products (in million RMB) in year t ; *Product-Oriented PatCount* denotes the natural logarithm of one plus the number of product-oriented patents solely applied by the focal firm.

We find that local firms' IUC activities and technology commercialization increase significantly after the establishment of university sub-campuses in neighboring provinces. We do not find more active IUC or higher technology commercialization among treated firms before the establishment. These results mitigate the concern of omitted variables related to local governments' policies or industry trends because, if the positive IUC experience-technology commercialization relation is driven by those omitted variables, IUC activities or technology commercialization should have increased significantly before the event.

References (Online Appendix)

- Acs, Z. J., Audretsch, D. B., & Feldman, M. P. (1992). The real effects of academic research: Comment. *American Economic Review*, 82, 363-367.
- Acs, Z. J., Audretsch, D. B., & Feldman, M. P. (1994). R&D spillovers and recipient firm size. *Review of Economics and Statistics*, 76, 336-340.
- Adams, J. D. (2005). Industrial R&D laboratories: Windows on black boxes?. *Essays in Honor of Edwin Mansfield: The Economics of R&D, Innovation, and Technological Change*, 99-107.
- Agrawal, A. (2006). Engaging the inventor: Exploring licensing strategies for university inventions and the role of latent knowledge. *Strategic Management Journal*, 27(1), 63-79.
- Agrawal, A. K. (2001). University-to-industry knowledge transfer: Literature review and unanswered questions. *International Journal of Management Reviews*, 3(4), 285-302.
- Alcácer, J., & Gittelman, M. (2006). Patent citations as a measure of knowledge flows: The influence of examiner citations. *Review of Economics and Statistics*, 88(4), 774-779.
- Appelbaum, R. P., Gebbie, M. A., Han, X., Stocking, G., & Kay, L. (2016). Will China's quest for indigenous innovation succeed? Some lessons from nanotechnology. *Technology in Society*, 46, 149-163.
- Arora, A., Belenzon, S., & Pataconi, A. (2018). The decline of science in corporate R&D. *Strategic Management Journal*, 39(1), 3-32.
- Arora, A., Belenzon, S., & Sheer, L. (2020). Knowledge spillovers and corporate investment in scientific research. *American Economic Review*, forthcoming.
- Audretsch, D. B., & Feldman, M. P. (1996). R&D spillovers and the geography of innovation and production. *American Economic Review*, 86(3), 630-640.
- Audretsch, D. B., & Stephan, P. E. (1996). Company-scientist locational links: The case of biotechnology. *American Economic Review*, 86(3), 641-652.
- Audretsch, D. B., Leyden, D. P., & Link, A. N. (2012). Universities as research partners in publicly supported entrepreneurial firms. *Economics of Innovation and New Technology*, 21(5-6), 529-545.
- Azagra-Caro, J. M., Archontakis, F., Gutiérrez-Gracia, A., & Fernández-de-Lucio, I. (2006). Faculty support for the objectives of university–industry relations versus degree of R&D cooperation: The importance of regional absorptive capacity. *Research Policy*, 35(1), 37-55.
- Baker, A. C., Larcker, D. F., & Wang, C. C. (2022). How much should we trust staggered difference-in-differences estimates?. *Journal of Financial Economics*, 144(2), 370-395.
- Becker, W., & Dietz, J. (2004). R&D cooperation and innovation activities of firms—evidence for the German manufacturing industry. *Research Policy*, 33(2), 209-223.
- Belderbos, R., Carree, M., & Lokshin, B. (2004). Cooperative R&D and firm performance. *Research Policy*, 33(10), 1477-1492.
- Belderbos, R., Carree, M., Diederer, B., Lokshin, B., & Veugelers, R. (2004). Heterogeneity in R&D cooperation strategies. *International Journal of Industrial Organization*, 22(8-9), 1237-1263.
- Belenzon, S., & Schankerman, M. (2013). Spreading the word: Geography, policy, and knowledge spillovers. *Review of Economics and Statistics*, 95(3), 884-903.
- Berchicci, L. (2013). Towards an open R&D system: Internal R&D investment, external knowledge acquisition and innovative performance. *Research Policy*, 42(1), 117-127.
- Boeing, P., & Mueller, E. (2019). Measuring China's patent quality: Development and validation of ISR indices. *China Economic Review*, 57, 101331.
- Boeing, P., Mueller, E., & Sandner, P. (2016). China's R&D explosion—Analyzing productivity effects across ownership types and over time. *Research Policy*, 45(1), 159-176.
- Branstetter, L. (2001). Exploring the Link between Academic Science and Industrial Innovation: The Case of California's Research Universities. University of California.
- Brehm, S., & Lundin, N. (2012). University–industry linkages and absorptive capacity: an empirical analysis of China's manufacturing industry. *Economics of Innovation and New Technology*, 21(8), 837-852.

- Broström, A. (2010). Working with distant researchers—Distance and content in university–industry interaction. *Research Policy*, 39(10), 1311-1320.
- Brown, M. A., Berry, L. G., & Goel, R. K. (1991). Guidelines for successfully transferring government-sponsored innovations. *Research Policy*, 20(2), 121-143.
- Bruneel, J., D’Este, P., & Salter, A. (2010). Investigating the factors that diminish the barriers to university–industry collaboration. *Research Policy*, 39(7), 858-868.
- Buenstorf, G., & Schacht, A. (2013). We need to talk—or do we? Geographic distance and the commercialization of technologies from public research. *Research Policy*, 42(2), 465-480.
- Caloghirou, Y., Tsakanikas, A., & Vonortas, N. S. (2001). University-industry cooperation in the context of the European framework programmes. *Journal of Technology Transfer*, 26(1), 153-161.
- Cassiman, B., & Veugelers, R. (2002). R&D cooperation and spillovers: Some empirical evidence from Belgium. *American Economic Review*, 92(4), 1169-1184.
- Cassiman, B., Veugelers, R., & Zuniga, P. (2008). In search of performance effects of (in) direct industry science links. *Industrial and Corporate Change*, 17(4), 611-646.
- Cengiz, D., Dube, A., Lindner, A., & Zipperer, B. (2019). The effect of minimum wages on low-wage jobs. *Quarterly Journal of Economics*, 134(3), 1405-1454.
- Che, Y., & Zhang, L. (2018). Human capital, technology adoption and firm performance: Impacts of China's higher education expansion in the late 1990s. *Economic Journal*, 128(614), 2282-2320.
- Chen, A., Patton, D., & Kenney, M. (2016). University technology transfer in China: A literature review and taxonomy. *Journal of Technology Transfer*, 41, 891-929.
- Chen, K., & Kenney, M. (2007). Universities/research institutes and regional innovation systems: the cases of Beijing and Shenzhen. *World Development*, 35(6), 1056-1074.
- Cockburn, I. M., & Henderson, R. M. (1998). Absorptive capacity, coauthoring behavior, and the organization of research in drug discovery. *Journal of Industrial Economics*, 46(2), 157-182.
- Cohen, W. M., Nelson, R. R., & Walsh, J. P. (2002). Links and impacts: the influence of public research on industrial R&D. *Management Science*, 48(1), 1-23.
- Colyvas, J., Crow, M., Gelijns, A., Mazzoleni, R., Nelson, R. R., Rosenberg, N., & Sampat, B. N. (2002). How do university inventions get into practice?. *Management Science*, 48(1), 61-72.
- D’Este, P., & Patel, P. (2007). University–industry linkages in the UK: What are the factors underlying the variety of interactions with industry?. *Research Policy*, 36(9), 1295-1313.
- D’Este, P., & Perkmann, M. (2011). Why do academics engage with industry? The entrepreneurial university and individual motivations. *Journal of Technology Transfer*, 36(3), 316-339.
- De Rassenfosse, G., & Raiteri, E. (2022). Technology protectionism and the patent system: Evidence from China. *Journal of Industrial Economics*, 70(1), 1-43.
- D’Este, P., & Iammarino, S. (2010). The spatial profile of university-business research partnerships. *Papers in Regional Science*, 89(2), 335-351.
- Eesley, C. E., Hsu, D. H., & Roberts, E. B. (2014). The contingent effects of top management teams on venture performance: Aligning founding team composition with innovation strategy and commercialization environment. *Strategic Management Journal*, 35(12), 1798-1817.
- Eisenhardt, K. M., & Schoonhoven, C. B. (1990). Organizational growth: Linking founding team, strategy, environment, and growth among US semiconductor ventures, 1978-1988. *Administrative Science Quarterly*, 35, 504-529.
- Eun, J. H., Lee, K., & Wu, G. (2006). Explaining the “University-run enterprises” in China: A theoretical framework for university–industry relationship in developing countries and its application to China. *Research Policy*, 35(9), 1329-1346.
- Feldman, M. P. (1994). Knowledge complementarity and innovation. *Small Business Economics*, 6, 363-372.
- Fisch, C. O., Block, J. H., & Sandner, P. G. (2016). Chinese university patents: quantity, quality, and the role of subsidy programs. *Journal of Technology Transfer*, 41, 60-84.

- Fisch, C., Sandner, P., & Regner, L. (2017). The value of Chinese patents: An empirical investigation of citation lags. *China Economic Review*, 45, 22-34.
- Fleming, L., & Sorenson, O. (2004). Science as a map in technological search. *Strategic Management Journal*, 25(8-9), 909-928.
- George, G., Zahra, S. A., & Wood Jr, D. R. (2002). The effects of business–university alliances on innovative output and financial performance: a study of publicly traded biotechnology companies. *Journal of Business Venturing*, 17(6), 577-609.
- Gittelman, M., & Kogut, B. (2003). Does good science lead to valuable knowledge? Biotechnology firms and the evolutionary logic of citation patterns. *Management Science*, 49(4), 366-382.
- Giuliani, E., Morrison, A., Pietrobelli, C., & Rabellotti, R. (2010). Who are the researchers that are collaborating with industry? An analysis of the wine sectors in Chile, South Africa and Italy. *Research Policy*, 39(6), 748-761.
- Godin, B., & Gingras, Y. (2000). Impact of collaborative research on academic science. *Science and Public Policy*, 27(1), 65-73.
- Gomes-Casseres, B., Hagedoorn, J., & Jaffe, A. B. (2006). Do alliances promote knowledge flows?. *Journal of Financial Economics*, 80(1), 5-33.
- Guan, J. C., Yam, R. C., & Mok, C. K. (2005). Collaboration between industry and research institutes/universities on industrial innovation in Beijing, China. *Technology Analysis & Strategic Management*, 17(3), 339-353.
- Hall, B. H., Link, A. N., & Scott, J. T. (2003). Universities as research partners. *Review of Economics and Statistics*, 85(2), 485-491.
- Hanel, P., & St-Pierre, M. (2006). Industry–university collaboration by Canadian manufacturing firms. *Journal of Technology Transfer*, 31(4), 485-499.
- Hewitt-Dundas, N. (2013). The role of proximity in university-business cooperation for innovation. *Journal of Technology Transfer*, 38(2), 93-115.
- Hong, W., & Su, Y. S. (2013). The effect of institutional proximity in non-local university–industry collaborations: An analysis based on Chinese patent data. *Research Policy*, 42(2), 454-464.
- Hong, W., 2008. Decline of the center: the decentralizing process of knowledge transfer of Chinese universities from 1985 to 2004. *Research Policy* 37 (4), 580–595.
- Hsu, D. H., Hsu, P. H., Zhou, T., & Ziedonis, A. A. (2021). Benchmarking U.S. university patent value and commercialization efforts: A new approach. *Research Policy*, 50(1).
- Jaffe, A. (1989a). Real effects of academic research. *American Economic Review*, 79(5), 957-70.
- Jaffe, A. B. (1989b). Real effects of academic research. *American Economic Review*, 957-970.
- Jensen, R., & Thursby, M. (2001). Proofs and prototypes for sale: The licensing of university inventions. *American Economic Review*, 91(1), 240-259.
- Kafouros, M., Wang, C., Piperopoulos, P., & Zhang, M. (2015). Academic collaborations and firm innovation performance in China: The role of region-specific institutions. *Research Policy*, 44(3), 803-817.
- Kaufmann, A., & Tödtling, F. (2001). Science–industry interaction in the process of innovation: the importance of boundary-crossing between systems. *Research Policy*, 30(5), 791-804.
- Klevorick, A. K., Levin, R. C., Nelson, R. R., & Winter, S. G. (1995). On the sources and significance of interindustry differences in technological opportunities. *Research Policy*, 24(2), 185-205.
- Kneller, R. (2007). The beginning of university entrepreneurship in Japan: TLOs and bioventures lead the way. *Journal of Technology Transfer*, 32, 435-456.
- Laursen, K., & Salter, A. (2006). Open for innovation: the role of openness in explaining innovation performance among UK manufacturing firms. *Strategic Management Journal*, 27(2), 131-150.
- Lee, Y. S. (1996). ‘Technology transfer’ and the research university: A search for the boundaries of university-industry collaboration. *Research Policy*, 25(6), 843-863.
- Lehmann, E. E., & Menter, M. (2016). University–industry collaboration and regional wealth. *Journal of Technology Transfer*, 41, 1284-1307.

- Lerner, J. (1995). Patenting in the Shadow of Competitors. *Journal of Law and Economics*, 38(2), 463-495.
- Levin, R. C., Klevorick, A. K., Nelson, R. R., Winter, S. G., Gilbert, R., & Griliches, Z. (1987). Appropriating the returns from industrial research and development. *Brookings Papers on Economic Activity*, 1987(3), 783-831.
- Liegsalz, J., & Wagner, S. (2013). Patent examination at the state intellectual property office in China. *Research Policy*, 42(2), 552-563.
- Lim, K. (2009). The many faces of absorptive capacity: spillovers of copper interconnect technology for semiconductor chips. *Industrial and Corporate Change*, 18(6), 1249-1284.
- Lin, J., Wu, H. M., & Wu, H. (2021). Could government lead the way? Evaluation of China's patent subsidy policy on patent quality. *China Economic Review*, 69, 101663.
- Link, A. N., & Rees, J. (1990). Firm size, university based research, and the returns to R&D. *Small Business Economics*, 2, 25-31.
- Link, A. N., & Siegel, D. S. (2005). University-based technology initiatives: Quantitative and qualitative evidence. *Research Policy*, 34(3), 253-257.
- Liu, X., & White, S. (2001). Comparing innovation systems: a framework and application to China's transitional context. *Research Policy*, 30(7), 1091-1114.
- Maietta, O. W. (2015). Determinants of university–firm R&D collaboration and its impact on innovation: A perspective from a low-tech industry. *Research Policy*, 44(7), 1341-1359.
- Mansfield, E. (1991). Academic research and industrial innovation. *Research Policy*, 20(1), 1-12.
- Mansfield, E. (1998). Academic research and industrial innovation: An update of empirical findings. *Research Policy*, 26(7-8), 773-776.
- Mansfield, E., & Lee, J. Y. (1996). The modern university: contributor to industrial innovation and recipient of industrial R&D support. *Research Policy*, 25(7), 1047-1058.
- Mora-Valentin, E. M., Montoro-Sanchez, A., & Guerras-Martin, L. A. (2004). Determining factors in the success of R&D cooperative agreements between firms and research organizations. *Research Policy*, 33(1), 17-40.
- Motohashi, K. (2005). University–industry collaborations in Japan: The role of new technology-based firms in transforming the National Innovation System. *Research Policy*, 34(5), 583-594.
- Motohashi, K. (2006). China's national innovation system reform and growing science industry linkage. *Asian Journal of Technology Innovation*, 14(2), 49-65.
- Motohashi, K., & Muramatsu, S. (2012). Examining the university industry collaboration policy in Japan: Patent analysis. *Technology in Society*, 34(2), 149-162.
- Motohashi, K., & Yun, X. (2007). China's innovation system reform and growing industry and science linkages. *Research Policy*, 36(8), 1251-1260.
- Mowery, D. C., & Ziedonis, A. A. (2014). Markets versus spillovers in outflows of university research. *Research Policy*, 44(1), 50-66.
- Mowery, D.C., Nelson, R.R., Sampat, B.N., Ziedonis, A.A., 2004. Ivory Tower and Industrial Innovation. Stanford University Press, Stanford, CA.
- Narin, F., Hamilton, K. S., & Olivastro, D. (1997). The increasing linkage between US technology and public science. *Research Policy*, 26(3), 317-330.
- Nelson, R. R. (1986). Institutions supporting technical advance in industry. *American Economic Review*, 76(2), 186-189.
- Nevens, T. M., Summe, G. L., & Uttal, B. (1990). Commercializing technology: what the best companies do. *Harvard Business Review*, 68(4), 154-163.
- Nieto, M. J., & Santamaría, L. (2007). The importance of diverse collaborative networks for the novelty of product innovation. *Technovation*, 27(6-7), 367-377.
- Obukhova, E., Wang, Y., & Li, J. (2012). The power of local networks: Returnee entrepreneurs, school ties, and firm performance. Working paper.
- Østergaard, C. R., Timmermans, B., & Kristinsson, K. (2011). Does a different view create something new? The effect of employee diversity on innovation. *Research Policy*, 40(3), 500-509.
- Pavitt, K. (1991). What makes basic research economically useful?. *Research Policy*, 20(2),

109-119.

- Peri, G. (2005). Determinants of knowledge flows and their effect on innovation. *Review of Economics and Statistics*, 87(2), 308-322.
- Perkmann, M., & Walsh, K. (2009). The two faces of collaboration: Impacts of university-industry relations on public research. *Industrial and Corporate Change*, 18(6), 1033-1065.
- Perkmann, M., King, Z., & Pavelin, S. (2011). Engaging excellence? Effects of faculty quality on university engagement with industry. *Research Policy*, 40(4), 539-552.
- Perkmann, M., Tartari, V., McKelvey, M., Autio, E., Broström, A., D'Este, P., ... & Sobrero, M. (2013). Academic engagement and commercialisation: A review of the literature on university-industry relations. *Research Policy*, 42(2), 423-442.
- Piezunka, H., & Grohsjean, T. (2023). Collaborations that hurt firm performance but help employees' careers. *Strategic Management Journal*, 44(3), 778-811.
- Powell, W. W., Koput, K. W., & Smith-Doerr, L. (1996). Interorganizational collaboration and the locus of innovation: Networks of learning in biotechnology. *Administrative Science Quarterly*, 116-145.
- Poyago-Theotoky, J., Beath, J., & Siegel, D. S. (2002). Universities and fundamental research: reflections on the growth of university-industry partnerships. *Oxford Review of Economic Policy*, 18(1), 10-21.
- Prager, D. J., & Omenn, G. S. (1980). Research, innovation, and university-industry linkages. *Science*, 207(4429), 379-384.
- Qian, C., Cao, Q., & Takeuchi, R. (2013). Top management team functional diversity and organizational innovation in China: The moderating effects of environment. *Strategic Management Journal*, 34(1), 110-120.
- Qiu, S., Liu, X., & Gao, T. (2017). Do emerging countries prefer local knowledge or distant knowledge? Spillover effect of university collaborations on local firms. *Research Policy*, 46(7), 1299-1311.
- Reuer, J. J., & Lahiri, N. (2014). Searching for alliance partners: Effects of geographic distance on the formation of R&D collaborations. *Organization Science*, 25(1), 283-298.
- Rosenberg, N., & Nelson, R. R. (1994). American universities and technical advance in industry. *Research Policy*, 23(3), 323-348.
- Scandura, A. (2016). University-industry collaboration and firms' R&D effort. *Research Policy*, 45(9), 1907-1922.
- Schartinger, D., Rammer, C., Fischer, M. M., & Fröhlich, J. (2002). Knowledge interactions between universities and industry in Austria: sectoral patterns and determinants. *Research Policy*, 31(3), 303-328.
- Segarra-Blasco, A., & Arauzo-Carod, J. M. (2008). Sources of innovation and industry-university interaction: Evidence from Spanish firms. *Research Policy*, 37(8), 1283-1295.
- Seo, E., & Somaya, D. (2022). Living it up at the Hotel California: Employee mobility barriers and collaborativeness in firms' innovation. *Organization Science*, 33(2), 766-784.
- Shi, D., Huang, K. G., Dang, J., & Zhou, S. (2022). Chinese patent citation data and its validity to measure patent quality. Working paper.
- Shubbak, M. H. (2019). The technological system of production and innovation: The case of photovoltaic technology in China. *Research Policy*, 48(4), 993-1015.
- Siegel, D. S., Waldman, D., & Link, A. (2003). Assessing the impact of organizational practices on the relative productivity of university technology transfer offices: an exploratory study. *Research Policy*, 32(1), 27-48.
- Siegel, D.S., Wright, M., 2015. University technology transfer offices, licensing, and startups. In: Link, A., Siegel, D, Wright, M. (Eds.), *The Chicago Handbook of University Technology Transfer and Academic Entrepreneurship*, pp. 1-40.
- Simonen, J., & McCann, P. (2008). Firm innovation: The influence of R&D cooperation and the geography of human capital inputs. *Journal of Urban Economics*, 64(1), 146-154.
- Sorenson, O., & Fleming, L. (2004). Science and the diffusion of knowledge. *Research Policy*, 33(10), 1615-1634.
- Sun, Y., Zhang, C., & Kok, R. A. (2020). The role of research outcome quality in the relationship between university research collaboration and technology transfer: Empirical results from

- China. *Scientometrics*, 122, 1003-1026.
- Tan, J. (2006). Growth of industry clusters and innovation: Lessons from Beijing Zhongguancun Science Park. *Journal of Business Venturing*, 21(6), 827-850.
- Tijssen, R. J. (2001). Global and domestic utilization of industrial relevant science: patent citation analysis of science–technology interactions and knowledge flows. *Research Policy*, 30(1), 35-54.
- Trajtenberg, M., Henderson, R., & Jaffe, A. (1997). University versus corporate patents: A window on the basicness of invention. *Economics of Innovation and New Technology*, 5(1), 19-50.
- Walsh, J. P., Lee, Y. N., & Nagaoka, S. (2016). Openness and innovation in the US: Collaboration form, idea generation and implementation. *Research Policy*, 45(8), 1660-1671.
- Wang, B., & Ma, J. (2007). Collaborative R&D: intellectual property rights between Tsinghua University and multinational companies. *Journal of Technology Transfer*, 32, 457-474.
- Wang, J., & Shapira, P. (2012). Partnering with universities: a good choice for nanotechnology start-up firms?. *Small Business Economics*, 38, 197-215.
- Wang, Y., & Lu, L. (2007). Knowledge transfer through effective university-industry interactions: Empirical experiences from China. *Journal of Technology Management in China*, 2(2), 119-133.
- Wang, Y., Huang, J., Chen, Y., Pan, X., & Chen, J. (2013). Have Chinese universities embraced their third mission? New insight from a business perspective. *Scientometrics*, 97, 207-222.
- Wu, W. (2007). Cultivating research universities and industrial linkages in China: The case of Shanghai. *World Development*, 35(6), 1075-1093.
- Wu, W. (2010). Managing and incentivizing research commercialization in Chinese Universities. *Journal of Technology Transfer*, 35, 203-224.
- Wu, W., & Zhou, Y. (2012). The third mission stalled? Universities in China's technological progress. *Journal of Technology Transfer*, 37, 812-827.
- Zhou, W. (2012). Determinants and effects of research partnerships in China's emerging market. *Contemporary Economic Policy*, 30(1), 129-147.
- Zucker, L. G., & Darby, M. R. (1996). Star scientists and institutional transformation: Patterns of invention and innovation in the formation of the biotechnology industry. *Proceedings of the National Academy of Sciences*, 93(23), 12709-12716.
- Zucker, L. G., & Darby, M. R. (2001). Capturing technological opportunity via Japan's star scientists: Evidence from Japanese firms' biotech patents and products. *Journal of Technology Transfer*, 26(1), 37-58.
- Zucker, L. G., Darby, M. R., & Armstrong, J. (1998). Geographically localized knowledge: Spillovers or markets?. *Economic Inquiry*, 36(1), 65-86.
- Zucker, L. G., Darby, M. R., & Brewer, M. B. (1994). Intellectual capital and the birth of US biotechnology enterprises.

E. Online Appendix Tables

Table OA.1: Summary of 70 Papers.

We summarize 70 related papers on their methodology/sample construction, key findings about industry-university collaboration, and empirical measures of innovation, knowledge transfers, and mechanisms.

Authors and Year	Method/Sample	Key findings on IUC	Measures of innovation/knowledge transfer	Mechanisms/factors	Theory/framework	Contingency
Acs, Audretsch, and Feldman, 1992	Quantitative. US state-industry and year, 1972-1977, 1979, and 1981	The interaction of university R&D and industry R&D (in the same state) positively explains firms' innovation output	(1) patents (2) commercialized inventions from SBIDB (Small Business Administration's Innovation Data Base)	Geographic spillover	Knowledge production function in log (Griliches 1979)	Under the "entrepreneurial regime," the innovation is more likely to result from basic research. Under the "routinized regime," an innovation is more likely to result from technological information from an R&D laboratory within the industry.
Acs, Audretsch, and Feldman, 1994	Quantitative. US state-technology area and year, 1982	The interaction of university R&D and industry R&D (in the same state) positively explains firms' innovation output	Commercialized inventions from SBIDB (Small Business Administration's Innovation Data Base)	Geographic spillover	Knowledge production function in log (Griliches 1979)	Firm size

Audretsch and Feldman, 1996	Quantitative, geographic concentration of innovation in US 163 industries in 1982	University research leads to geographic concentration of innovation	Commercialized inventions from SBIDB (Small Business Administration's Innovation Data Base)	Geographic spillover (Tacit knowledge); skilled labor availability	Romer (1986), Krugman (1991a, b), and Grossman and Helpman (1991) on spillovers. As Krugman (1991b) argue, there may be geographic boundaries to knowledge spillovers, particularly tacit knowledge	Industry R&D intensity; need for skilled workers
Feldman, 1994	Quantitative. US state-industry sample, 1982	Small firms benefit more from local university research	Commercialized inventions from SBIDB (Small Business Administration's Innovation Data Base)	Geographic spillover (communication costs and speed of technology race)	Krugman (1991a, b) regional specialization; Knowledge production function in log (Griliches 1979)	Geographic distance
Audretsch and Stephan, 1996	Quantitative, 312 scientists in biotech industry	The link between university-scientists and firms is not simply decided by locality. 40 of founders of biotech firms do not found firms locally	The co-location of university-based scientists and collaborating firms	Geographic spillover (tacit knowledge of Pisano et al. (1988)) is not everything. University-based scientists provide three key functions to biotech firms: university-based scientists facilitate knowledge transfer from university laboratories to the firm; they signal the quality of the firm's research; and they help		Age, Nobel prize, formality of ties (formal vs. informal)

				chart the scientific direction		
Link and Rees, 1990	Survey and quantitative. 1046 US firms, 1986-87	(1) the majority of firms engage in collaboration with universities for new product development. (2) firms engaging in IUC are better able to convert their R&D into productivity	Three collaboration formats with universities: consultants, contracted research projects, and graduate students used as research assistants. Collaboration incentives (expected results from the relationship) include: 'problem solving in production processes', 'product development', 'use of university computing facilities', 'use of other university facilities', and 'gaining access to students as future employees'.	Reduce R&D costs and access productive employees		Firm size
Jaffe, 1989	Quantitative. US state(-industry)-year panel, 1972-77, 1979, and 1981.	The interaction of university R&D and industry R&D (in the same state) positively explains firms' innovation output	Corporate patents	Geographic proximity (transfer of knowledge via personnel flows, informal information sharing, access to facilities etc.)	Knowledge production function in log (Griliches 1979)	

Mansfield, 1998	Survey and quantitative. 77 US firms in 1986-1994	About 15% (11%) of new products (processes) cannot realize without academic research. These new products account for 5% of sales (44 billion 1994 dollars). These new processes account for cost savings of about 2% (17 billion 1994 dollars). Also, the lag between academic research and industry application is 6 years on average	Firms' new products and processes commercialized over the period 1991-1994 that could not have been developed in the absence of recent academic research. Sales/cost-savings from these new products/prcoesses			
Mansfield, 1991	Survey and quantitative. 75 US firms in 1985	About 10% of new products and processes cannot realize without academic research. These new products account for 24 billion sales (1985 dollar), and these new processes save for 7 billion. Also, the lag between academic research and industry application is 7 years on average	Firms' new products and processes commercialized over the period 1975-1985 that could not have been developed in the absence of recent academic research. Sales/cost-savings from these new products/prcoesses			Science-dependence; firm-level R&D; firm size
Mansfield and Lee, 1996	Survey and quantitative. 70 US firms in 1985	Geographic distance determines a firm's support to university research	Each firm was asked to cite about five academic researchers whose work in the 1970s and 1980s contributed most importantly to the firm's new products and processes introduced in the 1980s	Tacit knowledge, face-to-face		Faculty quality

Zucker and Darby, 1996	Quantitative, 183 US geographic regions over 14 years (1976-1989).	Firms' collaboration with star scientists produce more new products	The number of new biotech firms (entrants) founded in a geographic region; growth in employment at biotech firms in a region; the number of new products.	Both geographic proximity and personal connection are needed (tacit knowledge; access to specialized human capital)		
Zucker, Darby, and Armstrong, 1998	Quantitative, 110 California biotech firms in 1989-1994	Firms' collaboration with star scientists produce more new products	The number of new products	Both geographic proximity and personal connection are needed (tacit knowledge; access to specialized human capital)		
Zucker, Darby, and Brewer, 1998	Quantitative, 751 companies in 183 US geographic regions over 14 years (1976-1989).	The number of new biotech firms increases with star scientists and university research in the region	The number of new biotech firms in a region	University innovation is subject to natural excludability, which arises from the complexity or tacitness of the information required to practice the innovation		
Zucker and Darby, 2001	Quantitative, 331 Japan biotech firms in 1986-1991	Firms' collaborations with star scientists have a large positive impact on firms' biotech patents and new products.	The numbers of U.S. biotechnology patents granted, numbers of new products	University innovation is subject to natural excludability, which arises from the complexity or tacitness of the information required to practice the innovation		

Cockburn and Hendersen, 1998	Survey and quantitative, 20 pharmaceutical firms, 1980-1994	Only 24% drugs, were developed with essentially no input from the public sector. Pharma firms' coauthorship with universities are positively related to their important patents. They interview managers found three additional factors (other than absorptive capacity): (1) recruiting the best people; (2) rewarding researchers on the basis of their standing in the public rank hierarchy; and (3) encouraging them to be actively engaged with their public sector counterparts.	New products, important patents (patents registered in 2 out of three TRIADIC areas)	Absorptive capacity (conversation, connection)	absorptive capacity	
Agrawal, 2001	Review	Summarizes the literature on the roles of university and firm characteristics in university-to-industry technology transfer. It constructs a general framework of the research in this area by: (1) providing an overview of the various related streams of research and how they fit together; (2) presenting a survey of the literature associated with each of these streams, including highlights from key papers; and (3) offering a view forward in terms of directions for future research.	Prior measures on the outcome of knowledge transfers: publications, patents, consulting, informal meetings, recruiting, licensing, joint ventures, research contracts, and personal exchange	Absorptive capacity, complementarity of channels	absorptive capacity, connectedness, tacit knowledge,	

Cohen, Nelson, and Walsh, 2002	Survey and descriptive. A 1994 survey of 1478 US R&D lab managers in the manufacturing sector.	Public research is critical to industry. Their data indicate that the largest percentage of respondents rated publications, conferences, and consulting as at least 'moderately important' knowledge transfer channels. These percentages are 41, 35, and 32%, respectively. The remaining channels are rated at least moderately important by a significantly smaller fraction of respondents, less than 20%. Close to 60% of industrial R&D labs indicate that they benefit from university research	The knowledge transfer channels include patents, informal information exchange, publications and reports, public meetings and conferences, recently hired graduates, licenses, joint or cooperative ventures, contract research, consulting, and temporary personnel exchanges.			Science-dependence
Colyvas, Crow, Gelijns, Mazzoleni, Nelson, Rosenberg, and Sampat, 2002	11 case studies in Columbia University and Stanford University	Researchers have incentive to commercialize their inventions. In most cases, firms get exclusive licenses from universities. Our strong conjecture, which we are exploring in these studies, is that both the role of patents, and the role of the university technology transfer offices, varies significantly from case to case.	Patent licensing	Researchers' incentive, technology transfer office practices		

Lim, 2009	Case study (and descriptive analysis) of copper interconnect technology of IBM	The author proposes 3 forms of absorptive capacity: disciplinary, domain specific, and encoded, which correspond to 3 different knowledge types, respectively: general scientific knowledge, solutions to specific technical problems, and knowledge embedded in tools and processes. University research is important to patents in this specific technology	patents, papers, hire of students	The author identifies 3 additional mechanisms for fostering connectedness, including: (1) cultivating university relationships by way of sponsoring research, collaborating with faculty, and recruiting graduate students; (2) participating in research consortia; and (3) partnering with other companies that do related scientific research.	absorptive capacity	
Audretsch, Leyden, and Link, 2012	Model and quantitative. 92 firms in US Department of Energy's Small Business Innovation Research (SBIR) in 1992	larger firms or firms with founders who have an academic background are more likely to partner with a university in a project		Firm size, founder background		
Branstetter, 2001	30,000 utility patents granted in the US over the 1981-1996	knowledge spillovers from academic science to invention are highly concentrated in a small subset of technological fields and geographic regions.	Citations to university papers	Geographic proximity		Science-dependence, geographic proximity

Hall, Link, and Scott, 2003	Survey and quantitative analysis. A survey of 352 research projects funded by the Advanced Technology Program in the US in 1991-1997	Little is known about the types of roles that universities play in such research partnerships or about the economic consequences associated with those roles. Universities are more likely to partner in new technological fields where R&D is closer to science, and such fields can be more uncertain and difficult.	Termination of project, expected commercialization likelihood	(1) access to complementary research activity and research results; (2) access to key university personnel; (3) expanding its boundaries while at the same time eliminating market transactions for research services.		Science-dependence
Pavitt, 1998	Review	Technologically dynamic firms depend heavily on the close proximity of publicly funded academic research and related training. Academic research really facilitates firms' capacity of businesses to solve complex problems		Academic research helps technology problem-solving through: useful knowledge inputs; engineering design tools and techniques; instrumentation; trained scientists and engineers; background knowledge; membership of national and international professional networks; spin-off firms	Tacit knowledge	
Godin and Gingras, 2000	Canadian Bibliographic database covers the years 1980 to 1997	Canadian industry significantly increase collaborations with universities from 1980 to 1995				

Poyago-Theotoky, Beath, and Siegel, 2002	Review	This paper identifies the determinants of university-industry collaboration. They conclude that we still know very little about the global impact of the rise of university-industry partnerships	The formation of partnership has the following benefits: (i) the acquisition of knowledge that can ultimately generate additional profit and (ii) skill/knowledge enhancement of its own scientific workforce.	Risks for universities; risk for firms; Complementarity; costs and benefits from principal-agent issue related to contracting of collaboration	Principal-agent issues; tacit knowledge; absorptive capacity	
Caloghirou, Tsakanikas, and Vonortas, 2001	6,300 research joint ventures (RJVs) in 42 nations that received funding from the European Framework Programmes in 1983-1996.	The ratio of these RJVs involving a university has risen considerably since (from 56% in 1983 to 67% in 1996). Larger or longer RJVs are more likely involve universities. 90% of biotech RJVs involve universities. Surveyed firms report that universities are the most likely partner (more than clients and suppliers)	The formation of RJVs with universities; Such RJVs benefit firms' knowledge base, new product development, new process	Size and length of RJV		Science-dependence; project size and project length
Jensen and Thursby, 2001	A survey of 62 U.S. research universities, 1991-1995	The vast majority (71%) of university-based inventions required some inventor involvement in development. TTO managers indicated that convincing faculty to disclose inventions is a major challenge. Licensed academic inventions are usually far from being readily marketable.				

Broström, 2010	Survey and quantitative. A survey to 425 R&D managers in Swedish engineering firms, 2004-2006	Direct interactions matter. Linkages in geographical proximity are more likely than distant linkages to generate impulses to innovation and create significant learning effects at the firm.	Questions on whether interactions with universities help	Geographic proximity (collaborations often are generated in close, continuous interaction, trust that frequently arise in interaction within close geographical proximity)	Tacit knowledge, von Hippel's (1994) sticky knowledge	Life cycle
Mowery and Ziedonis, 2014	Quantitative. US, invention, patenting, and licensing records from the technology transfer offices at Columbia University, Stanford University, and the University of California	Between the two channels of IUC, knowledge "spillovers" (i.e., positive externalities from university research) and "market-mediated" channels such as technology licensing or various types of employment knowledge flows from universities, the market-based channels are more geographically concentrated	Licensing agreements and patent citations	Geographic proximity (tacit knowledge)		
Bruneel, D'Este, and Salter, 2010	Survey and quantitative. Large scale of survey in the UK: 3,431 individuals from 600 organizations in 2005-2006	They propose orientation- and transaction-related barriers for interactions. They examine the determinants of obstacles. highlight several channels of interactions and discuss the mutual trust (the mutual understanding and repeated interactions) as a key moderator. Universities, when effectively engaged with, can significantly contribute to industry innovation and problem-solving. Prior	Key factors: collaboration experience; breadth of interaction channels; trust	Mutual trust	Absorptive capacity; transaction costs;	Trust

		collaboration is an important factor to reduce barriers				
Agrawal, 2006	124 licensed MIT inventions, 1998-1999	Inventors' involvement is positively associated with the likelihood and extent of products' commercial success. It refers to knowledge that is not codified but is codifiable as "latent knowledge".	Commercialization indicator and royalties per year	Tacit knowledge and complexity		
D'Este and Iammarino, 2010	Descriptive and quantitative. 2,210 collaborative research grants in the UK in 1999-2003	Both geographical proximity and research quality are positively associated with the frequency of university-industry partnerships	Collaboration with university; distance to the collaborating university	geographical proximity and research quality		Science-dependence, research quality/prestige
Buenstorf and Schacht, 2013	Quantitative. 2300 inventions of the German Max Planck Society in Germany in 1980-2004	They analyze the effects of distance on licensees' commercial success, using the existence and amount of licensing royalty payments as a measure of such success, and do not find a significant relation	The commercialization of projects, royalty income	Face-to-face, time costs for university researchers	Tacit knowledge, sticky knowledge	
Belenzon and Schankerman, 2013	Quantitative. Patents in the U.S. in 1975-2007.	They study how geography affects university knowledge spillovers using data on citations to university patents and	Citations to university patents and publications	(1) local information and (2) policies for commercializing university innovation.		States' local development policies, human capital mobility (noncompete

		scientific publications. Citations to university patents are constrained by state border; and citations to publications are less localized in states.				labor laws, reliance on in-state educated scientists, and lower rates of interstate scientific labor mobility), university quality
Schartinger, Rammer, Fischer, and Fröhlich, 2002	Survey and quantitative. Austrian universities (421 departments from 12 universities)	Summarize firms' viewpoints on interactions with universities: Contract research and consulting; Collaborative research; Financing of university research assistants by firms; Joint supervision of Ph.D. and Masters theses are the top 4. It also summarizes universities' viewpoints on interactions with industry. University departments with prior contract research experience is more likely to engage in future collaborations with industry.	Interactions with universities: joint research, contract research, personell mobility, training and lectures	Face-to-face (Social capital/trust), tacit knowledge	NIS	Industry R&D intensity; science-dependence
Becker and Dietz, 2004	Quantitative. 2048 German manufacturing firms 1990-1992	Firms rating science institutions higher are more likely to form collaboration. Joint R&D is used to complement internal resources in the innovation process, enhancing the innovation input and output measured by the intensity of in-house R&D or the realization of product innovations.	R&D, product innovation, cooperation	Internal R&D enhances firms incentive to engage in collaboration	Transaction costs	

Belderbos, Carree, Diederer, Lokshin, and Veugelers, 2004	Quantitative. 2149 innovative Dutch firms in 1996 and 1998	Firms rating universities as important source for innovation tend to form collaborations with universities	Collaborations with university	Rating the importance of university source	Absorptive capacity, transaction costs, resource-based view	
Belderbos, Carree, and Lokshin, 2004	Quantitative. 2056 Dutch firms in 1996 and 1998	Firms collaborating with universities or benefiting more from university spillovers produce more new product sales	new product sales	Collaborator types		
Nieto and Santamaria, 2007	Quantitative. 1300 Spanish firms in 1998-2002	Collaboration experience is important for product innovation novelty. However, the collaboration with universities does not lead to higher product novelty	Novelty of product innovation	Absorptive capacity, path dependence	Transaction costs, resource-based view, Evolutionary theory, Evolutionary theory,	
Kneller, 2007	Descriptive, Japan	Based on a university's licensing record, joint research tends to happen with big companies	Corporate donation, a large proportion of engineering and materials/chemistry inventions are attributed to joint research, start-up, spin-off			Japan's legal environments and patent laws
Motohashi, 2005	Survey and quantitative. RIETIs Survey of 7442 Japanese firms in 2003	Smaller firms achieve higher productivity through collaboration with universities than large firms. About 70% of firms engaging in R&D activities engage in R&D collaborations of some form -- 40% of firms engaging in such collaborations engage in UIC activities.	Current collaboration with university, expected future collaboration with university, patents, value-added	Technology absorptive capacity		Firms' own R&D

Kaufmann and Todtling, 2001	Surveys. 517 firms in Europe in 1996	Collaborating with universities predict more new products. It is important to have diversified inputs	New products	Universities providing new knowledge, create knowledge interactively with firms, and stimulate innovation projects.	NIS; self-referential systems	
Klevorick, Levin, Nelson, and Winter, 1995	Survey and descriptive. 600 managers in 130 business lines in the U.S. in 1983-1984	The relevance of science/university research to industry innovation varies by industries	Survey on whether science/university research is relevant for industry innovation	(1) advances in scientific understanding and technique expand the pool of technological opportunities. (2) technological advances in other industries and in other institutions in the economy can enrich technological opportunities within a given industry. (3) there are positive feedbacks from an industry's technological advances in one period that open up new technological opportunities		Science-dependence
Nelson, 1986	Survey and descriptive. 600 managers in 130 business lines in the U.S. in 1983-1984	Firms reporting that the benefit more from university research also spend more on R&D	R&D intensity			

Perkmann et al., 2013	Review	A systematic review of research on academic scientists' involvement in university-industry collaboration activities. The authors identify the individual, organisational and institutional antecedents and consequences of academic engagement, and then compare these findings with the antecedents and consequences of commercialisation.				
Walsh, Lee, and Nagaoka, 2016	Quantitative. 1900 responses of US patent inventors in 2000-2003	Collaboration with universities lead to better innovation quality, but does not lead to more commercialized patents	Invention quality rated by inventors; whether a patent is commercialized	Collaborator types	Transaction costs; evolutionary economics;	
Laurson and Salter, 2014	Quantitative. 2655 manufacturing firms drawn from the UK Innovation Survey in 2001	Only 27% of UK firms indicate that they draw from UK universities. Firms which use many other external sources of knowledge (such as competitors, suppliers and customers, private research institutes, fairs and trade associations, etc.) also tend to use university research more intensively. Firms with more internal R&D are also more likely to collaborate with universities	The degree of importance of university research	In-house R&D, size		Firm age
Adams, 2005	Quantitative. 220 labs of 116 firms in a survey in the US in 1991-1996	University spillovers appear to be more localized than industry spillovers. Firms go to	R&D budget devoted to academic research; learning from which university/firm	Academic R&D in related fields		

		neighboring universities for advice, research, and students				
Maietta, 2015	Quantitative. 1744 Italian food companies for the 1995-2006	Determinants of university-firm R&D collaboration. Geopraghic proximity affects product innovation. Firms collaborating with universities invest more in R&D, and produce more product or process innovation	R&D investment; R&D collaborations with universities; product innovation; process innovation	Geographic proximity	NIS; knowledge production function of Griliches	
Wang and Shapira, 2012	230 nanotechnology firms in the US in 1996-2005	The study analyzes the resources possessed by university scientists in 3 formats (intellectual capital, social capital, and positional capital) on the performance of parnter firms.	Winning SBIR awards	resource spillovers; university scientists		
Sun, Zhang, and Kok, 2020	Quantitative. 1784 Chinese universities' patents in USPTO between 1985 and 2014	University research collaboration promotes technology transfer directly (and indirectly through improving the quality of research outcomes)	Patent reassignment as a measure for technology transfer; collaboration with firms	Direct effects (connection) and indirect effects	Resource-based view; Triple Helix theory; NIH	University research quality
Motohashi and Yun, 2007	NBS's Survey on Science and Technology Activities in China, 1996-2002	The first attempt to document large-scale science and industry linkage activities, and their determinants	Outsourcing of science and technology projects	Absorptive capacity	NIS	organization types, science dependence

Guan, Yam, and Mok, 2005	Survey of 950 Chinese firms (Beijing), 1993-1995	13% (18%) of surveyed firms (high-tech firms) report university research is innovation source. Firms with partnership with universities produce more innovation. Such collaboration relationship is less efficient in terms of economic performance indicators such as innovation sales and profit ratios.	new product sales, profits	Barriers to the acquisition of research results from universities include (i) lack of efficient communication channels for the research results; (ii) the research results are difficult to commercialize; (iii) the research results are immature; and (iv) the research results have high uncertainty from the market place perspective.		Organization types (SOEs or not)
Wu, 2007	Case studies with descriptive statistics: Fudan University and Shanghai Jiaotong University	It examines the interactions between two elite universities in Shanghai (Fudan University and Shanghai Jiaotong University) and the metropolitan economy. In particular	R&D collaboration, licensing, spin-off		NIS	
Wu, 2010	Case studies with descriptive statistics: Fudan University and Shanghai Jiaotong University	Faculty research output grows more rapidly in academic papers than patents and licensing. The diffusion of university research occurs primarily through contracts for technology services, patent licensing and sales, and university-affiliated enterprises. Some faculty prefers to work with firms directly through consultancy or other informal arrangements.	R&D collaboration, licensing, spin-off			

Motohashi, 2006	NBS's Survey on Science and Technology Activities in China, 1996-2002	In 2002, about 23% of S&T firms are conducting S&T outsourcing to universities or PRIs.	Research collaboration, co-patents		NIS	Science-dependence
Hong, 2008	Quantitative. pair of provinces in China, 1985-2004	The decentralizing/localizing trend in university–industry collaborations due to the changing economic and institutional context.	Patents coassigned to firms and universities	Geographic spillover (Tacit knowledge), institutional proximity (network)	Tacit knowledge, institutional thickness	
Liu and White, 2001	Descriptive analyses. 64,230 patents and 1,069,172 papers in China from 1992 to 1997.	This paper focuses on summary statistics, and argue that universities have played a limited role in technology transfers and commercialization due to lack of incentives and weak IP protection	Joint patents, joint papers	Incentives from universities, IP protection	National innovation system	
Eun, Lee, and Wu, 2006	Qualitative analyses, China	Chinese universities launched a large number of spin-offs. They attribute such an explosion to the low absorptive capacity of industrial firms and weak institutional environments.		Universitirs' propensity to pursue economic gains, industry firms' absorptive capacity, and improved external environment.	Triple Helix (university, industry, and government) (Etzkowitz, 1998, 2002); Transaction cost economics (Williamson, 1975, 1985, 1991, 1999)); resource-based view (Penrose (1959) and Richardson (1972))	Universities' propensity to pursue economic gains, industry firms' absorptive capacity, and improved external environment.

Chen, Patton, and Kenney, 2016	Review of 191 papers in English or Chinese on Chinese university technology transfers	More publications in Chinese in the past; an increasing trend in empirical and quantitative analyses. Articles are aggregated into following the five themes: (1) government policy and the national innovation system (NIS), (2) university-operated enterprises (UOEs), university science parks (USPs), and spin-offs, (3) university-industry linkages (UILs), (4) university policy and technology transfer offices (TTOs), and (5) university patents and licensing. Key determinants of universities' technology transfers: University R&D funding, Govt. provided R&D, Enterprise provided R&D, Quantity of R&D personnel, and Quality of R&D personnel	Prior studies focus on Chinese firms' patents, new products, and firm growth	sticky knowledge in university-industry linkages; Absorptive capacity of firms related to technology transfer; Geography and proximity	The NIS perspective pioneered by Lundvall (1992) and Nelson (1993) is a theoretical frame capable of explaining the ways in which different social institutions interact to produce and commercialize innovations.	
Wu and Zhou, 2012	Review of several surveys in China	There is mixed literature on the ratio and frequency of firms actively seeking collaboration with universities or considering university research as key source. Difficulties and challenges are listed. Greater autonomy for universities is needed	Partner with university, or consider university research important source	faculty resources and their expertise by seeking technical support, information, and R&D personnel support.		

Hong and Su, 2019	Quantitative. Chinese patents, 1985-2004	The distance between firms and universities negatively explains collaboration, but the relation is strengthened/mitigated by geographic, organizational, institutional, social proximity, and university prestige	Patents coassigned to firms and universities	geographic proximity, organizational proximity, institutional proximity, social proximity, and university prestige	geographic proximity (local spillover, tacit knowledge increased with distance Audretsch and Stephan (1996)), organizational proximity (transaction costs of Williamson (1975, 1985) and institutional thickness), institutional proximity (transaction costs and institutional thickness), social proximity (social network, tacit knowledge), and university prestige (reputation and legitimacy)	organizational proximity, institutional proximity, social proximity, and university prestige
Kafouros, Wang, Piperopoulos, and Zhang, 2015	375 innovative Chinese firms, 2008-2011	The relation between academic collaboration and new product sales is an inverted U shape: it increases and then decreases	New product sales; academic collaboration			IP protection; international openness; research quality of universities
Chen and Kenney, 2007	Case study and descriptive analysis in China	Universities have played an important role in the development of largest high	Spin-off, university patents, technology transfer contract, revenue		NIS, regional innovation system (RIS)	

		technology clusters (Beijing and Shenzhen) in China				
Wang and Lu, 2007	Even study of a company which collaborate with Tsinghua University	It presents a strategic framework of successful knowledge transfer in university-industry interactions in China	New product development; Managing the process of interactions;	knowledge gap and knowledge stickiness.	Von Hippel's concept of sticky information; regional innovation system	
Wang and Ma, 2007	Descriptive and case study based on Tsinghua U.	Discuss the legal protection of jointly assigned technology property. A more basic research can lead to more commercializable products in more sectors.	Four different models of collaboration projects: Commission Project; Joint Research Project; Joint Development Project; Joint Research Organization			
Wang, Huang, Chen, Pan, and Chen, 2013	Top 100 firms in electronics industry in China	Firms that directly and systematically collaborate with universities for their own purposes will be more efficient and achieve more fruitful results when their partners have complementary resources and knowledge	Patent counts	Drive to reduce costs; interpersonal contact	Resource-based view; transaction cost theory	
Zhou, 2012	Quantitative. 1,500 Chinese innovating firms, 1998-2000	Firms with higher internal R&D are more likely to partner with universities. Partnership with universities predict more patents but not more new products	Collaboration with universities, patents, new products	IP protection, internal R&D	NIS; Resource-based view; transaction cost theory	Firm size, IP protection
Brehm and Lundin, 2012	Quantitative. 20,000 large- and medium-sized companies in China in 1998-2004	University collaboration leads to better innovation output or commercialization when industries have higher absorptive capacity	new product sales; new product export; patents; co-authored papers	Co-authored papers; absorptive capacity	absorptive capacity; activity-based view	Industry-specificity in the knowledge source (external vs. internal)

George, Zahra, and Wood, 2002	Quantitative. Alliances of 147 biotechnology firms in the US	Firms with university linkages will have significantly more alliances, and produce more new products and patents, and spend more on R&D	(1) university linkages, (2) alliance characteristics, (3) R&D investment, (4) patents; (5) new products	University link	Transaction costs; absorptive capacity	
Appelbaum, Gebbie, Han, Stocking, and Kay, 2016	Survey. Interviews with scientists, engineers, entrepreneurs, and venture capitalists in the nanotech industry in 2012	It reviews why Chinese nanotechnology firms did not succeed along the following dimensions: (1) deficit in the basic research; (2) research culture; (3) lack of incentive for university scientists to engage in commercial innovation or commercializing their inventions		government policies; culture issues;		

Table OA.2: Robustness Checks for Table 2.

We re-estimate Table 2 by not taking the logarithmic value of the dependent variable. The outcome variable and all control variables are winsorized at their 1st and 99th percentiles. Numbers in parentheses denote standard errors clustered by firms. ***, **, * indicate significance levels of 1%, 5%, and 10%, respectively.

Dept Var = New Product Sales in Linear Form				
	Panel A: Patent-Based IUC		Panel B: Paper-Based IUC	
	(1)	(2)	(1)	(2)
IUC Dummy	3.7604*** (1.3453)		1.7483** (0.7361)	
IUC Count		4.2761*** (1.3228)		4.4218*** (0.9603)
Total Sales	31.1992*** (1.4265)	31.1711*** (1.4269)	31.1916*** (1.4257)	30.9390*** (1.4222)
Patent Portfolio Size	1.4711*** (0.1213)	1.4544*** (0.1216)	1.4956*** (0.1220)	1.4406*** (0.1203)
R&D Intensity	38.5794*** (9.9706)	38.5634*** (9.9678)	38.4704*** (9.9697)	38.2522*** (9.9563)
Total Assets	0.3641*** (0.1331)	0.3670*** (0.1330)	0.3596*** (0.1333)	0.3773*** (0.1329)
Age	-0.6787*** (0.1400)	-0.6734*** (0.1399)	-0.6867*** (0.1403)	-0.6770*** (0.1402)
Cash Ratio	1.2501*** (0.2660)	1.2529*** (0.2660)	1.2390*** (0.2660)	1.2308*** (0.2660)
Capital Expenditure Intensity	1.8491*** (0.1696)	1.8512*** (0.1696)	1.8493*** (0.1697)	1.8566*** (0.1696)
Profitability Ratio	2.7420*** (0.7310)	2.7453*** (0.7309)	2.7731*** (0.7296)	2.8529*** (0.7301)
Sales Growth	-0.0600 (0.0412)	-0.0603 (0.0412)	-0.0597 (0.0412)	-0.0573 (0.0412)
Export Ratio	3.1966*** (0.3511)	3.1976*** (0.3511)	3.1953*** (0.3511)	3.1965*** (0.3509)
Leverage Ratio	0.2514 (0.2638)	0.2539 (0.2637)	0.2459 (0.2637)	0.2483 (0.2638)
Labor Ratio	48.2471*** (6.8790)	48.2632*** (6.8778)	47.7545*** (6.8856)	47.5911*** (6.8776)
Wage per Employee	0.0087*** (0.0014)	0.0086*** (0.0014)	0.0087*** (0.0014)	0.0083*** (0.0014)
Subsidy Ratio	19.5536*** (6.5777)	19.5038*** (6.5781)	19.5743*** (6.5776)	19.4039*** (6.5876)
#Obs	784,025	784,025	784,025	784,025
#Firms	92,521	92,521	92,521	92,521
R-squared	0.8199	0.8199	0.8199	0.8200
Firm FE	YES	YES	YES	YES
Province-Year FE	YES	YES	YES	YES
Industry-Year FE	YES	YES	YES	YES

Table OA.3: Robustness Checks for Table 3.

We re-estimate Table 3 by not taking the logarithmic value of the dependent variable. The outcome variable and all control variables are winsorized at their 1st and 99th percentiles. Numbers in parentheses denote standard errors clustered by firms. ***, **, * indicate significance levels of 1%, 5%, and 10%, respectively.

Panel A: Dept Var = Product-Oriented PatCount in Linear Form				
	Panel A.1: Patent-Based IUC		Panel A.2: Paper-Based IUC	
	(1)	(2)	(1)	(2)
IUC Dummy	0.7227*** (0.0923)		0.3205*** (0.0420)	
IUC Count		0.8298*** (0.1021)		0.4639*** (0.0511)
Patent Portfolio Size	0.1981*** (0.0109)	0.1947*** (0.0109)	0.2026*** (0.0110)	0.1986*** (0.0109)
R&D Intensity	-3.9309*** (0.5788)	-3.9125*** (0.5789)	-3.9618*** (0.5789)	-3.9558*** (0.5786)
Total Assets	0.2898*** (0.0088)	0.2899*** (0.0088)	0.2890*** (0.0088)	0.2890*** (0.0088)
Age	-0.0522*** (0.0083)	-0.0509*** (0.0083)	-0.0539*** (0.0083)	-0.0529*** (0.0083)
Cash Ratio	0.0511** (0.0214)	0.0518** (0.0214)	0.0490** (0.0214)	0.0488** (0.0214)
Capital Expenditure Intensity	-0.0479*** (0.0110)	-0.0473*** (0.0110)	-0.0479*** (0.0110)	-0.0471*** (0.0110)
Profitability Ratio	0.9553*** (0.0502)	0.9559*** (0.0502)	0.9599*** (0.0502)	0.9625*** (0.0502)
Sales Growth	-0.0206*** (0.0032)	-0.0207*** (0.0032)	-0.0205*** (0.0032)	-0.0205*** (0.0032)
Export Ratio	0.1422*** (0.0225)	0.1422*** (0.0225)	0.1421*** (0.0225)	0.1415*** (0.0224)
Leverage Ratio	0.0633*** (0.0212)	0.0633*** (0.0212)	0.0622*** (0.0212)	0.0617*** (0.0212)
Labor Ratio	12.6723*** (0.6262)	12.6498*** (0.6259)	12.5905*** (0.6262)	12.5319*** (0.6259)
Wage per Employee	0.0035*** (0.0002)	0.0035*** (0.0002)	0.0035*** (0.0002)	0.0035*** (0.0002)
Subsidy Ratio	3.2269*** (0.5510)	3.2207*** (0.5504)	3.2350*** (0.5513)	3.2355*** (0.5513)
#Obs	784,025	784,025	784,025	784,025
#Firms	92,521	92,521	92,521	92,521
R-squared	0.4626	0.4629	0.4625	0.4628
Firm FE	YES	YES	YES	YES
Province-Year FE	YES	YES	YES	YES
Industry-Year FE	YES	YES	YES	YES

(Continued on the next page)

(Table OA.3 continued)

Panel B: Dept Var = Product-Oriented PatCite in Linear Form				
	Panel B.1: Patent-Based IUC		Panel B.2: Paper-Based IUC	
	(1)	(2)	(1)	(2)
IUC Dummy	0.0149*** (0.0048)		0.0052** (0.0025)	
IUC Count		0.0118*** (0.0044)		0.0078*** (0.0025)
Patent Portfolio Size	0.0014*** (0.0005)	0.0014*** (0.0005)	0.0015*** (0.0005)	0.0015*** (0.0005)
R&D Intensity	0.0686 (0.0491)	0.0686 (0.0491)	0.0679 (0.0491)	0.0680 (0.0491)
Total Assets	0.0121*** (0.0005)	0.0121*** (0.0005)	0.0121*** (0.0005)	0.0121*** (0.0005)
Age	-0.0007 (0.0005)	-0.0007 (0.0005)	-0.0007 (0.0005)	-0.0007 (0.0005)
Cash Ratio	0.0032** (0.0016)	0.0032** (0.0016)	0.0032** (0.0016)	0.0032** (0.0016)
Capital Expenditure Intensity	-0.0015 (0.0010)	-0.0014 (0.0010)	-0.0015 (0.0010)	-0.0014 (0.0010)
Profitability Ratio	0.0465*** (0.0039)	0.0465*** (0.0039)	0.0465*** (0.0039)	0.0466*** (0.0039)
Sales Growth	-0.0005** (0.0003)	-0.0005** (0.0003)	-0.0005** (0.0003)	-0.0005** (0.0003)
Export Ratio	0.0066*** (0.0014)	0.0066*** (0.0014)	0.0066*** (0.0014)	0.0065*** (0.0014)
Leverage Ratio	0.0014 (0.0015)	0.0014 (0.0015)	0.0013 (0.0015)	0.0013 (0.0015)
Labor Ratio	0.6167*** (0.0430)	0.6167*** (0.0430)	0.6156*** (0.0430)	0.6145*** (0.0430)
Wage per Employee	0.0001*** (0.0000)	0.0001*** (0.0000)	0.0001*** (0.0000)	0.0001*** (0.0000)
Subsidy Ratio	0.2091*** (0.0437)	0.2092*** (0.0437)	0.2093*** (0.0437)	0.2093*** (0.0437)
#Obs	784,025	784,025	784,025	784,025
#Firms	92,521	92,521	92,521	92,521
R-squared	0.2888	0.2888	0.2888	0.2888
Firm FE	YES	YES	YES	YES
Province-Year FE	YES	YES	YES	YES
Industry-Year FE	YES	YES	YES	YES

Table OA.4: Industry-University Collaboration and Other Quality Measures of Product-Oriented Patents.

We execute pooled regressions to estimate the association between industry-university collaboration (IUC) and a firm's quality measures of product-oriented patents. Specifically, we regress the dependent variables, *Product-Oriented PatBasic* in year $t+1$ in Panel A, *Product-Oriented PatExplore* in year $t+1$ in Panel B, and *Product-Oriented TechBreadth* in year $t+1$ in Panel C on measures of joint patenting and joint research as independent variables in year $t-4$ to t . As the dependent variables, *Product-Oriented PatBasic* denotes the ratio of academic papers cited over total backward citations of product-oriented patents that are solely applied by the focal firm. *Product-Oriented PatExplore* denotes the ratio of product-oriented exploratory patents over the number of product-oriented patents that are solely applied by the focal firm. A patent is defined as exploratory if its primary IPC codes are different from those of patents applied in the past. *Product-Oriented TechBreadth* denotes the average number of unique primary IPC codes per product-oriented patent that is solely applied by the focal firm. If a patent has the following five detailed IPC codes: C22C19/00 (primary IPC is C22), C23C4/00 (primary IPC is C23), C23C4/02 (primary IPC is C23), H01L23/36 (primary IPC is H01), and H05K7/20 (primary IPC is H05), then its applicable primary IPCs include C22, C23, H01, and H05. As the independent variables, *Patent-Based (Paper-Based) IUC Dummy* equals one if the focal firm has an IUC patent (paper); otherwise it equals to zero. *Patent-Based (Paper-Based) IUC Count* denotes the number of patents applied by (papers published by) both a university and the focal firm. We also control for innovation-related variables such as *Patent Portfolio Size* and *R&D Intensity*. We further control for firm characteristics such as *Total Assets* (in billion RMB), *Age*, *Cash Ratio*, *Capital Expenditure Intensity*, *Profitability Ratio*, *Sales Growth*, *Export Ratio*, *Leverage Ratio*, *Labor Ratio*, *Wage per Employee*, *Subsidy Ratio*, as well as firm fixed effects, province-year fixed effects, and industry-year fixed effects. All control variables are defined in Table 1. Sample period of t is from 1998 to 2013. The outcome variable and all control variables are winsorized at their 1st and 99th percentiles. Numbers in parentheses denote standard errors clustered by firms. ***, **, * indicate significance levels of 1%, 5%, and 10%, respectively.

Panel A: Dept Var = Product-Oriented PatBasic				
	Panel A.1: Patent-Based IUC		Panel A.2: Paper-Based IUC	
	(1)	(2)	(1)	(2)
IUC Dummy	0.0073*** (0.0013)		0.0027*** (0.0006)	
IUC Count		0.0076*** (0.0013)		0.0035*** (0.0006)
#Obs	784,025	784,025	784,025	784,025
#Firms	92,521	92,521	92,521	92,521
R-squared	0.2350	0.2352	0.2349	0.2350
Innovation-Related Controls	YES	YES	YES	YES
Firm Characteristics Controls	YES	YES	YES	YES
Firm FE	YES	YES	YES	YES
Province-Year FE	YES	YES	YES	YES
Industry-Year FE	YES	YES	YES	YES
Panel B: Dept Var = Product-Oriented PatExplore				
	Panel B.1: Patent-Based IUC		Panel B.2: Paper-Based IUC	
	(1)	(2)	(1)	(2)
IUC Dummy	0.0472*** (0.0062)		0.0116*** (0.0035)	
IUC Count		0.0348*** (0.0054)		0.0102*** (0.0034)
#Obs	784,025	784,025	784,025	784,025
#Firms	92,521	92,521	92,521	92,521
R-squared	0.2454	0.2454	0.2454	0.2454
Innovation-Related Controls	YES	YES	YES	YES
Firm Characteristics Controls	YES	YES	YES	YES
Firm FE	YES	YES	YES	YES
Province-Year FE	YES	YES	YES	YES
Industry-Year FE	YES	YES	YES	YES
Panel C: Dept Var = Product-Oriented TechBreadth				
	Panel C.1: Patent-Based IUC		Panel C.2: Paper-Based IUC	
	(1)	(2)	(1)	(2)
IUC Dummy	0.0434*** (0.0105)		0.0194*** (0.0056)	
IUC Count		0.0336*** (0.0095)		0.0218*** (0.0057)
#Obs	784,025	784,025	784,025	784,025
#Firms	92,521	92,521	92,521	92,521
R-squared	0.3696	0.3695	0.3695	0.3696
Innovation-Related Controls	YES	YES	YES	YES
Firm Characteristics Controls	YES	YES	YES	YES
Firm FE	YES	YES	YES	YES
Province-Year FE	YES	YES	YES	YES
Industry-Year FE	YES	YES	YES	YES

Table OA.5: Robustness Checks for Table 4.

We re-estimate Table 4 by using *Ratio of Backward Citations to IUC Patents* and *Ratio of Backward Citations to IUC Papers* as alternative measures of *Absorptive Capacity*. Specifically, *Ratio of Backward Citations to IUC Patents* of a firm is measured by its ratio of backward citations to IUC patents divided by total backward citations of patents; *Ratio of Backward Citations to IUC Papers* of a firm is measured by its ratio of backward citations to IUC papers divided by total backward citations of papers. The outcome variable and all control variables are winsorized at their 1st and 99th percentiles. Numbers in parentheses denote standard errors. ***, **, * indicate significance levels of 1%, 5%, and 10%, respectively.

Panel A: Ratio of Backward Citations to IUC Patents as Measure of Absorptive Capacity						
Panel A.1: IUC measured in Dummy						
Dept Var =	Panel A.1.1: Patent-Based IUC			Panel A.1.2: Paper-Based IUC		
	New Product Sales (1)	Product-Oriented PatCount (2)	Product-Oriented PatCite (3)	New Product Sales (1)	Product-Oriented PatCount (2)	Product-Oriented PatCite (3)
IUC × High Group	0.1076*** (0.0245)	0.2063*** (0.0190)	0.0187*** (0.0044)	0.1630*** (0.0228)	0.3230*** (0.0180)	0.0305*** (0.0042)
IUC	0.0461*** (0.0132)	0.0579*** (0.0103)	0.0074*** (0.0024)	0.0307*** (0.0066)	0.0319*** (0.0052)	0.0028** (0.0012)
#Obs	784,025	784,025	784,025	784,025	784,025	784,025
#Firms	92,521	92,521	92,521	92,521	92,521	92,521
R-squared	0.8274	0.4442	0.3026	0.8274	0.4443	0.3027
Innovation-Related Controls	YES	YES	YES	YES	YES	YES
Firm Characteristics Controls	YES	YES	YES	YES	YES	YES
Firm FE	YES	YES	YES	YES	YES	YES
Province-Year FE	YES	YES	YES	YES	YES	YES
Industry-Year FE	YES	YES	YES	YES	YES	YES
Panel A.2: IUC measured in Count						
Dept Var =	Panel A.2.1: Patent-Based IUC			Panel A.2.2: Paper-Based IUC		
	New Product Sales (1)	Product-Oriented PatCount (2)	Product-Oriented PatCite (3)	New Product Sales (1)	Product-Oriented PatCount (2)	Product-Oriented PatCite (3)
IUC × High Group	0.0529*** (0.0188)	0.0960*** (0.0143)	0.0046 (0.0033)	0.1223*** (0.0140)	0.1987*** (0.0112)	0.0227*** (0.0026)
IUC	0.0467*** (0.0134)	0.0696*** (0.0104)	0.0081*** (0.0024)	0.0503*** (0.0060)	0.0420*** (0.0048)	0.0037*** (0.0011)
#Obs	784,025	784,025	784,025	784,025	784,025	784,025
#Firms	92,521	92,521	92,521	92,521	92,521	92,521
R-squared	0.8274	0.4442	0.3026	0.8274	0.4444	0.3027
Innovation-Related Controls	YES	YES	YES	YES	YES	YES
Firm Characteristics Controls	YES	YES	YES	YES	YES	YES
Firm FE	YES	YES	YES	YES	YES	YES
Province-Year FE	YES	YES	YES	YES	YES	YES
Industry-Year FE	YES	YES	YES	YES	YES	YES
Panel B: Ratio of Backward Citations to IUC Papers as Measure of Absorptive Capacity						
Panel B.1: IUC measured in Dummy						
Dept Var =	Panel B.1.1: Patent-Based IUC			Panel B.1.2: Paper-Based IUC		
	New Product Sales (1)	Product-Oriented PatCount (2)	Product-Oriented PatCite (3)	New Product Sales (1)	Product-Oriented PatCount (2)	Product-Oriented PatCite (3)
IUC × High Group	0.0438 (0.0295)	0.1132*** (0.0230)	0.0179*** (0.0053)	0.1010*** (0.0156)	0.0622*** (0.0124)	0.0078*** (0.0029)
IUC	0.0678*** (0.0125)	0.0950*** (0.0097)	0.0094*** (0.0022)	0.0200*** (0.0071)	0.0390*** (0.0056)	0.0031** (0.0013)
#Obs	784,025	784,025	784,025	784,025	784,025	784,025
#Firms	92,521	92,521	92,521	92,521	92,521	92,521
R-squared	0.8274	0.4441	0.3026	0.8274	0.4441	0.3026
Innovation-Related Controls	YES	YES	YES	YES	YES	YES
Firm Characteristics Controls	YES	YES	YES	YES	YES	YES
Firm FE	YES	YES	YES	YES	YES	YES
Province-Year FE	YES	YES	YES	YES	YES	YES
Industry-Year FE	YES	YES	YES	YES	YES	YES
Panel B.2: IUC measured in Count						
Dept Var =	Panel B.2.1: Patent-Based IUC			Panel B.2.2: Paper-Based IUC		
	New Product Sales (1)	Product-Oriented PatCount (2)	Product-Oriented PatCite (3)	New Product Sales (1)	Product-Oriented PatCount (2)	Product-Oriented PatCite (3)
IUC × High Group	0.0386 (0.0237)	0.0868*** (0.0181)	0.0123*** (0.0042)	0.0496*** (0.0121)	0.0053 (0.0095)	0.0013 (0.0022)
IUC	0.0646*** (0.0110)	0.1002*** (0.0083)	0.0079*** (0.0019)	0.0512*** (0.0068)	0.0662*** (0.0054)	0.0063*** (0.0012)
#Obs	784,025	784,025	784,025	784,025	784,025	784,025
#Firms	92,521	92,521	92,521	92,521	92,521	92,521
R-squared	0.8274	0.4442	0.3026	0.8274	0.4442	0.3026
Innovation-Related Controls	YES	YES	YES	YES	YES	YES
Firm Characteristics Controls	YES	YES	YES	YES	YES	YES
Firm FE	YES	YES	YES	YES	YES	YES
Province-Year FE	YES	YES	YES	YES	YES	YES
Industry-Year FE	YES	YES	YES	YES	YES	YES

Table OA.6: Robustness Checks for Table 5.

We re-estimate Table 5 by using *Ratio of Paper Publication over Patent Issuance* as an alternative measure of *Science Dependence*. Specifically, *Ratio of Paper Publication over Patent Issuance* of an industry is measured by its ratio of paper publications divided by patent issuance. The outcome variable and all control variables are winsorized at their 1st and 99th percentiles. Numbers in parentheses denote standard errors. ***, **, * indicate significance levels of 1%, 5%, and 10%, respectively.

Panel A: IUC measured in Dummy							
Dept Var =	Panel A.1: Patent-Based IUC			Panel A.2: Paper-Based IUC			
	New Product Sales (1)	Product-Oriented PatCount (2)	Product-Oriented PatCite (3)	New Product Sales (1)	Product-Oriented PatCount (2)	Product-Oriented PatCite (3)	
IUC × High Group	0.1324*** (0.0328)	0.1865*** (0.0252)	0.0100* (0.0058)	0.0193*** (0.0069)	0.0200*** (0.0055)	0.0028** (0.0013)	
IUC	0.0589*** (0.0122)	0.0905*** (0.0095)	0.0112*** (0.0022)	0.1142*** (0.0146)	0.1655*** (0.0114)	0.0097*** (0.0026)	
#Obs	784,025	784,025	784,025	784,025	784,025	784,025	
#Firms	92,521	92,521	92,521	92,521	92,521	92,521	
R-squared	0.8274	0.4442	0.3026	0.8274	0.4442	0.3026	
Innovation-Related Controls	YES	YES	YES	YES	YES	YES	
Firm Characteristics Controls	YES	YES	YES	YES	YES	YES	
Firm FE	YES	YES	YES	YES	YES	YES	
Province-Year FE	YES	YES	YES	YES	YES	YES	
Industry-Year FE	YES	YES	YES	YES	YES	YES	

Panel B: IUC measured in Dummy							
Dept Var =	Panel B.1: Patent-Based IUC			Panel B.2: Paper-Based IUC			
	New Product Sales (1)	Product-Oriented PatCount (2)	Product-Oriented PatCite (3)	New Product Sales (1)	Product-Oriented PatCount (2)	Product-Oriented PatCite (3)	
IUC × High Group	0.0860*** (0.0252)	0.1410*** (0.0189)	0.0050 (0.0044)	0.1093*** (0.0109)	0.1269*** (0.0086)	0.0081*** (0.0020)	
IUC	0.0584*** (0.0107)	0.0936*** (0.0081)	0.0095*** (0.0019)	0.0369*** (0.0064)	0.0332*** (0.0051)	0.0044*** (0.0012)	
#Obs	784,025	784,025	784,025	784,025	784,025	784,025	
#Firms	92,521	92,521	92,521	92,521	92,521	92,521	
R-squared	0.8274	0.4442	0.3026	0.8274	0.4443	0.3026	
Innovation-Related Controls	YES	YES	YES	YES	YES	YES	
Firm Characteristics Controls	YES	YES	YES	YES	YES	YES	
Firm FE	YES	YES	YES	YES	YES	YES	
Province-Year FE	YES	YES	YES	YES	YES	YES	
Industry-Year FE	YES	YES	YES	YES	YES	YES	

Table OA.7: Robustness Checks for Table 6.

We re-estimate Table 6 by using *Inverse of Location Distance* as an alternative measure of *Geographic Proximity*. Specifically, *Inverse of Location Distance* of a firm is measured by the inverse of the weighted average of the distance between the focal firm and its collaborating universities. The outcome variable and all control variables are winsorized at their 1st and 99th percentiles. Numbers in parentheses denote standard errors. ***, **, * indicate significance levels of 1%, 5%, and 10%, respectively.

Panel A: IUC measured in Dummy						
Dept Var =	Panel A.1: Patent-Based IUC			Panel a.2: Paper-Based IUC		
	New Product Sales (1)	Product-Oriented PatCount (2)	Product-Oriented PatCite (3)	New Product Sales (1)	Product-Oriented PatCount (2)	Product-Oriented PatCite (3)
IUC × High Group	0.0670*** (0.0231)	0.0123 (0.0180)	0.0033 (0.0041)	0.1391*** (0.0319)	0.1251*** (0.0246)	0.0267*** (0.0057)
IUC	0.0510*** (0.0142)	0.1098*** (0.0110)	0.0113*** (0.0025)	0.0365*** (0.0065)	0.0476*** (0.0051)	0.0039*** (0.0012)
#Obs	784,025	784,025	784,025	784,025	784,025	784,025
#Firms	92,521	92,521	92,521	92,521	92,521	92,521
R-squared	0.8274	0.4441	0.3026	0.8274	0.4441	0.3026
Innovation-Related Controls	YES	YES	YES	YES	YES	YES
Firm Characteristics Controls	YES	YES	YES	YES	YES	YES
Firm FE	YES	YES	YES	YES	YES	YES
Province-Year FE	YES	YES	YES	YES	YES	YES
Industry-Year FE	YES	YES	YES	YES	YES	YES

Panel B: IUC measured in Count						
Dept Var =	Panel B.1: Patent-Based IUC			Panel B.2: Paper-Based IUC		
	New Product Sales (1)	Product-Oriented PatCount (2)	Product-Oriented PatCite (3)	New Product Sales (1)	Product-Oriented PatCount (2)	Product-Oriented PatCite (3)
IUC × High Group	0.0418** (0.0192)	0.0156 (0.0146)	0.0046 (0.0034)	0.0457*** (0.0171)	0.0805*** (0.0135)	0.0151*** (0.0031)
IUC	0.0546*** (0.0128)	0.1110*** (0.0097)	0.0084*** (0.0022)	0.0626*** (0.0059)	0.0617*** (0.0047)	0.0055*** (0.0011)
#Obs	784,025	784,025	784,025	784,025	784,025	784,025
#Firms	92,521	92,521	92,521	92,521	92,521	92,521
R-squared	0.8274	0.4442	0.3026	0.8274	0.4442	0.3026
Innovation-Related Controls	YES	YES	YES	YES	YES	YES
Firm Characteristics Controls	YES	YES	YES	YES	YES	YES
Firm FE	YES	YES	YES	YES	YES	YES
Province-Year FE	YES	YES	YES	YES	YES	YES
Industry-Year FE	YES	YES	YES	YES	YES	YES

Table OA.8: Robustness Checks for Table 10.

We execute pooled regressions to estimate the effects of industry-university collaboration (IUC) on a firm's future performance of technology commercialization conditional on technological complementarity. Specifically, the dependent variables are *New Product Sales* in year $t+1$ in a natural logarithm form in Columns (1), *Product-Oriented PatCount* in year $t+1$ in a natural logarithm form in Columns (2), and *Product-Oriented PatCite* in year $t+1$ in a natural logarithm form in Columns (3), respectively. As the independent variables, *Patent-Based IUC* and *Paper-Based IUC* are measured in *Dummy* and *Count* in Panels A and B, respectively. All firm-year observations are split into two groups according to their measures of *Technological Complementarity*: if a *measure* is higher than the median, then it is included in the high group; otherwise, it is included in the low group. We measure *Technological Complementarity* with *Ratio of Synergistic Technology Classes*. Specifically, *Ratio of Synergistic Technology Classes* of a firm is measured by its ratio of synergistic technology class pairs divided by total technology class pairs. A technology class X of firm F and class Y of the firm's collaborating university U are synergistic if they are included in at least one other patent. We also control for innovation-related variables such as *Patent Portfolio Size* and *R&D Intensity*. We further control for firm characteristics such as *Total Assets* (in billion RMB), *Age*, *Cash Ratio*, *Capital Expenditure Intensity*, *Profitability Ratio*, *Sales Growth*, *Export Ratio*, *Leverage Ratio*, *Labor Ratio*, *Wage per Employee*, *Subsidy Ratio*, as well as firm fixed effects, province-year fixed effects, and industry-year fixed effects. All control variables are defined in Table 1. Sample period of t is from 1998 to 2013. The outcome variable and all control variables are winsorized at their 1st and 99th percentiles. Numbers in parentheses denote standard errors. ***, **, * indicate significance levels of 1%, 5%, and 10%, respectively.

Panel A: IUC measured in Dummy						
Dept Var =	Panel A.1: Patent-Based IUC			Panel A.2: Paper-Based IUC		
	New Product Sales (1)	Product-Oriented PatCount (2)	Product-Oriented PatCite (3)	New Product Sales (1)	Product-Oriented PatCount (2)	Product-Oriented PatCite (3)
IUC × High Group	0.0161 (0.0207)	0.0851*** (0.0161)	0.0085** (0.0037)	0.1042*** (0.0285)	0.0228 (0.0223)	0.0144*** (0.0051)
IUC	0.0668*** (0.0158)	0.0679*** (0.0125)	0.0079*** (0.0029)	0.0370*** (0.0065)	0.0504*** (0.0051)	0.0042*** (0.0012)
#Obs	784,025	784,025	784,025	784,025	784,025	784,025
#Firms	92,521	92,521	92,521	92,521	92,521	92,521
R-squared	0.8273	0.4441	0.3026	0.8274	0.4441	0.3026
Innovation-Related Controls	YES	YES	YES	YES	YES	YES
Firm Characteristics Controls	YES	YES	YES	YES	YES	YES
Firm FE	YES	YES	YES	YES	YES	YES
Province-Year FE	YES	YES	YES	YES	YES	YES
Industry-Year FE	YES	YES	YES	YES	YES	YES
Panel B: IUC measured in Count						
Dept Var =	Panel B.1: Patent-Based IUC			Panel B.2: Paper-Based IUC		
	New Product Sales (1)	Product-Oriented PatCount (2)	Product-Oriented PatCite (3)	New Product Sales (1)	Product-Oriented PatCount (2)	Product-Oriented PatCite (3)
IUC × High Group	0.0099 (0.0176)	0.0818*** (0.0135)	0.0083*** (0.0031)	0.0652*** (0.0173)	0.0140 (0.0136)	0.0081*** (0.0031)
IUC	0.0669*** (0.0140)	0.0690*** (0.0110)	0.0055** (0.0025)	0.0621*** (0.0059)	0.0670*** (0.0046)	0.0062*** (0.0011)
#Obs	784,025	784,025	784,025	784,025	784,025	784,025
#Firms	92,521	92,521	92,521	92,521	92,521	92,521
R-squared	0.8274	0.4442	0.3026	0.8274	0.4442	0.3026
Innovation-Related Controls	YES	YES	YES	YES	YES	YES
Firm Characteristics Controls	YES	YES	YES	YES	YES	YES
Firm FE	YES	YES	YES	YES	YES	YES
Province-Year FE	YES	YES	YES	YES	YES	YES
Industry-Year FE	YES	YES	YES	YES	YES	YES

Table OA.9: Staggered Difference-in-Differences Analysis Using Promotion of Local-Level University Science Parks to National-Level Ones.

We utilize the promotion of a local-level university science park as a national-level university science park to be a shock to local IUC activities and execute staggered difference-in-differences regressions. We include the following dependent variables defined in year t : in Panel A, *Patent-Based IUC (Paper-Based IUC)* denotes the natural logarithm of one plus the number of patents applied by (papers published by) both a university and the focal firm. In Panel B, *New Product Sales* denotes the natural logarithm of one plus the output value of new products (in million RMB); *Product-Oriented PatCount* denotes the natural logarithm of one plus the number of product-oriented patents solely applied by the focal firm; *Product-Oriented PatCite* denotes the average forward-five-year citations of product-oriented patents solely applied by the focal firm. A firm-year observation is included in the sample if its city already has a university science park in year t . As the independent variable in Columns (1), *National University Science Park (Post)* equals one for all firms in this city if a city's local-level university science parks have been promoted as national-level ones; otherwise it equals zero. In Columns (2), *National University Science Park (Post)* is decomposed into ten event year related dummy variables. We further control for firm characteristics such as *Total Assets* (in billion RMB), *Age*, *Cash Ratio*, *Capital Expenditure Intensity*, *Profitability Ratio*, *Sales Growth*, *Export Ratio*, *Leverage Ratio*, *Labor Ratio*, *Wage per Employee*, *Subsidy Ratio*, as well as firm fixed effects, year fixed effects, and number-of-years-since-USP fixed effects. All control variables are defined in Table 1. Sample period of t is from 1998 to 2013. All control variables are winsorized at their 1st and 99th percentiles. Numbers in parentheses denote standard errors. ***, **, * indicate significance levels of 1%, 5%, and 10%, respectively.

Panel A: Dept Var = Industry-University Collaboration				
	Panel A.1: Patent-Based IUC		Panel A.2: Paper-Based IUC	
	(1)	(2)	(1)	(2)
National University Science Park (Post)	0.0078*** (0.0018)		0.0110*** (0.0018)	
Event Year <= -5		0.0037 (0.0058)		-0.0067 (0.0058)
Event Year = -4		0.0020 (0.0058)		-0.0052 (0.0059)
Event Year = -3		-0.0049 (0.0040)		0.0021 (0.0040)
Event Year = -2		0.0017 (0.0037)		-0.0035 (0.0037)
Event Year = -1		-0.0028 (0.0034)		0.0024 (0.0034)
Event Year = +1		0.0001 (0.0032)		0.0048 (0.0032)
Event Year = +2		0.0077** (0.0032)		0.0070** (0.0032)
Event Year = +3		0.0088*** (0.0030)		0.0104*** (0.0031)
Event Year = +4		0.0052* (0.0031)		0.0138*** (0.0031)
Event Year >= +5		0.0134*** (0.0028)		0.0193*** (0.0029)
#Obs	107,635	107,635	107,635	107,635
#Firms	14,045	14,045	14,045	14,045
R-squared	0.3384	0.3387	0.5528	0.5530
Innovation-Related Controls	YES	YES	YES	YES
Firm Characteristics Controls	YES	YES	YES	YES
Firm FE	YES	YES	YES	YES
Year FE	YES	YES	YES	YES
Number of Years Since USP FE	YES	YES	YES	YES

(Continued on the next page)

(Table OA.9 continued)

Panel B: Dept Var = Technology Commercialization						
	Panel B.1: New Product Sales		Panel B.2: Product-Oriented PatCount		Panel B.3: Product-Oriented PatCite	
	(1)	(2)	(1)	(2)	(1)	(2)
National University Science Park (Post)	0.3987*** (0.0079)		0.0373*** (0.0082)		0.0063** (0.0031)	
Event Year <= -5		-0.0029 (0.0256)		0.0225 (0.0238)		-0.0084 (0.0090)
Event Year = -4		-0.0134 (0.0258)		-0.0191 (0.0196)		-0.0060 (0.0074)
Event Year = -3		-0.0226 (0.0175)		-0.0150 (0.0162)		-0.0024 (0.0061)
Event Year = -2		0.0047 (0.0162)		-0.0088 (0.0149)		0.0049 (0.0056)
Event Year = -1		0.0091 (0.0149)		0.0031 (0.0122)		0.0007 (0.0046)
Event Year = +1		0.1968*** (0.0141)		0.0042 (0.0115)		0.0036 (0.0043)
Event Year = +2		0.4382*** (0.0142)		0.0634*** (0.0123)		0.0152*** (0.0046)
Event Year = +3		0.4175*** (0.0134)		0.0689*** (0.0122)		0.0165*** (0.0046)
Event Year = +4		0.4290*** (0.0136)		0.0763*** (0.0128)		0.0217*** (0.0048)
Event Year >= +5		0.5490*** (0.0125)		0.0786*** (0.0156)		0.0246*** (0.0059)
#Obs	107,635	107,635	107,635	107,635	107,635	107,635
#Firms	14,045	14,045	14,045	14,045	14,045	14,045
R-squared	0.7937	0.7957	0.7292	0.7294	0.4695	0.4696
Innovation-Related Controls	YES	YES	YES	YES	YES	YES
Firm Characteristics Controls	YES	YES	YES	YES	YES	YES
Firm FE	YES	YES	YES	YES	YES	YES
Year FE	YES	YES	YES	YES	YES	YES
Number of Years Since USP FE	YES	YES	YES	YES	YES	YES

Table OA.10: Staggered Difference-in-Differences Analysis Using Effects of Establishments of University Sub-Campuses across Provincial Borders.

We utilize the establishment of a university sub-campus as a shock to IUC activities of firms nearby but across provincial borders and execute staggered difference-in-differences regressions. We include the following dependent variables defined in year t : in Panel A, *Patent-Based IUC (Paper-Based IUC)* denotes the natural logarithm of one plus the number of patents applied by (papers published by) both a university and the focal firm. In Panel B, *New Product Sales* denotes the natural logarithm of one plus the output value of new products (in million RMB); *Product-Oriented PatCount* denotes the natural logarithm of one plus the number of product-oriented patents solely applied by the focal firm; *Product-Oriented PatCite* denotes the average forward-five-year citations of product-oriented patents solely applied by the focal firm. As the independent variable in Columns (1), *University Sub-Campus (Post)* equals one for all firms in cities that have experienced the establishment of a university campus within a 100km distance but in another province; otherwise it equals zero. In Columns (2), *University Sub-Campus (Post)* is decomposed into ten event year related dummy variables. A firm will be excluded from the sample if it is in a city that has at least one nearby university campus before the start of our sample period of that has at least one university campus by the end of our sample period. We also control for innovation-related variables such as *Patent Portfolio Size* and *R&D Intensity*. We further control for firm characteristics such as *Total Assets* (in billion RMB), *Age*, *Cash Ratio*, *Capital Expenditure Intensity*, *Profitability Ratio*, *Sales Growth*, *Export Ratio*, *Leverage Ratio*, *Labor Ratio*, *Wage per Employee*, *Subsidy Ratio*, as well as firm fixed effects and province-year fixed effects. All control variables are defined in Table 1. Sample period of t is from 1998 to 2013. All control variables are winsorized at their 1st and 99th percentiles. Numbers in parentheses denote standard errors. ***, **, * indicate significance levels of 1%, 5%, and 10%, respectively.

Panel A: Dept Var = Industry-University Collaboration				
	Panel A.1: Patent-Based IUC		Panel A.2: Paper-Based IUC	
	(1)	(2)	(1)	(2)
University Sub-Campus (Post)	0.0038*** (0.0012)		0.0073*** (0.0019)	
Event Year ≤ -5		0.0019 (0.0026)		-0.0028 (0.0041)
Event Year = -4		0.0003 (0.0030)		0.0049 (0.0048)
Event Year = -3		0.0013 (0.0025)		0.0040 (0.0039)
Event Year = -2		0.0016 (0.0023)		0.0017 (0.0037)
Event Year = -1		0.0012 (0.0022)		0.0017 (0.0035)
Event Year = +1		0.0019 (0.0020)		0.0005 (0.0032)
Event Year = +2		0.0044** (0.0020)		0.0118*** (0.0032)
Event Year = +3		0.0039** (0.0019)		0.0097*** (0.0031)
Event Year = +4		0.0078*** (0.0020)		0.0128*** (0.0032)
Event Year ≥ +5		0.0087*** (0.0018)		0.0146*** (0.0030)
#Obs	144,510	144,510	144,510	144,510
#Firms	20,128	20,128	20,128	20,128
R-squared	0.2781	0.2782	0.4995	0.4996
Innovation-Related Controls	YES	YES	YES	YES
Firm Characteristics Controls	YES	YES	YES	YES
Firm FE	YES	YES	YES	YES
Province-Year FE	YES	YES	YES	YES

(Continued on the next page)

(Table OA.10 continued)

Panel B: Dept Var = Technology Commercialization						
	Panel B.1: New Product Sales		Panel B.2: Product-Oriented PatCount		Panel B.3: Product-Oriented PatCite	
	(1)	(2)	(1)	(2)	(1)	(2)
University Sub-Campus (Post)	0.2292*** (0.0064)		0.0278*** (0.0050)		0.0043*** (0.0015)	
Event Year <= -5		0.0227 (0.0140)		0.0011 (0.0110)		0.0002 (0.0033)
Event Year = -4		-0.0134 (0.0161)		-0.0003 (0.0127)		-0.0006 (0.0038)
Event Year = -3		0.0198 (0.0132)		0.0010 (0.0105)		0.0012 (0.0031)
Event Year = -2		0.0045 (0.0125)		0.0014 (0.0099)		0.0011 (0.0030)
Event Year = -1		0.0008 (0.0117)		-0.0008 (0.0092)		0.0011 (0.0028)
Event Year = +1		0.0159 (0.0109)		0.0003 (0.0086)		0.0019 (0.0026)
Event Year = +2		0.0569*** (0.0106)		0.0342*** (0.0084)		0.0055** (0.0025)
Event Year = +3		0.4280*** (0.0103)		0.0436*** (0.0082)		0.0057** (0.0025)
Event Year = +4		0.4658*** (0.0108)		0.0273*** (0.0085)		0.0041 (0.0026)
Event Year >= +5		0.4555*** (0.0100)		0.0487*** (0.0079)		0.0103*** (0.0024)
#Obs	144,510	144,510	144,510	144,510	144,510	144,510
#Firms	20,128	20,128	20,128	20,128	20,128	20,128
R-squared	0.7518	0.7600	0.6897	0.6898	0.4127	0.4128
Innovation-Related Controls	YES	YES	YES	YES	YES	YES
Firm Characteristics Controls	YES	YES	YES	YES	YES	YES
Firm FE	YES	YES	YES	YES	YES	YES
Province-Year FE	YES	YES	YES	YES	YES	YES

Table OA.11: Variable list of the NBS data.

We provide a comprehensive list of variables in the NBS data. The variables labelled in bold are those used in our empirical analysis.

<i>Panel A: Background Information</i>		<i>Panel B: Balance Sheet</i>		<i>Panel C: Income Statement & Cash Flow Statement (part 1)</i>		<i>Panel C: Income Statement & Cash Flow Statement (part 2)</i>	
Variable Name	Item Name (translated in English)	Variable Name	Item Name (translated in English)	Variable Name	Item Name (translated in English)	Variable Name	Item Name (translated in English)
qymc	Firm Name	ldzchj	Current Assets	gyxsczjxgd	Total Sales	sj	Tax
frdm	Code of Legal Person	yszkje	Accounts Receivable	xcpcz	New Product Sales	cpxlsxjffj	Tax and Surcharge on Sales
frdbxm	Name of Legal Person	ch	Inventories	gyzcxjxgd	Total Industrial Output Value	zysj	Main Business Tax
zw	Position of Legal Person	ccp	Finished Products	gyzjz	Industrial Added Value	ccbxf	Property Insurance Premiums
dqdm	Location	gdzchj	Physical Assets	yysr	Operating Revenue	lddybxf	Unemployment Insurance Premiums
yzbm	Zipcode	scjyy	Physical Assets (used in production process)	qtsr	Other Revenue	ldbxf	Workers Insurance Expenses
cp1	Name of Product 1	ljzj	Total Depreciation	zyywsr	Main Business Revenue	yllybxf	Medical Insurance Expenses
cp2	Name of Product 2	jsjs	Computers	tzsy	Income from Investment	ylbxf	Pension
cp3	Name of Product 3	qzsj	Micro-Computers	yywsr	Non-Operating Revenue	zfgjj	Housing Reserves
hylb	Industry	wxjdyzchj	Intangibles and Deferred Assets	cpxsbc	Cost Of Goods Sold	ewfy	Financial Expenses
djzclx	Registration Type	wxzc	Intangibles	zycb	Main Business Costs	lxzc	Interest Expenses
gykgqk	State Own Enterprise (dummy)	zczj	Total Assets	cpxsfy	Sales Expenses	btsr	Subsidies Received
kysjn	Establishment Year	ldfzjh	Current Liabilities	ggf	Advertisement Expenses	yjsds	Income Tax Payable
kysjy	Establishment Month	yfzk	Accounts Payable	glfy	Administration Expenses	yflr	Profits Payable
cyhddwshj	Number of Business Units	cqfzjh	Long-Term Liabilities	yyfy	Operating Expenses	bnyfgzze	Wages Payable
qygm	Firm Size Category	fzhj	Total Liabilities	clf	Travel Expenses	zyywyfgzze	Wages Payable (for main business)
qzgy	Light/Heavy Industry (binary)	syzqyhj	Total Equity	ghjf	Labor Union Expenditure	bnyfflfe	Welfare Payable
dzyj	Email	sszb	Paid-in Capital	bgf	Office Allowance	zyywyfflfe	Welfare Payable (for main business)
wz	Website	gjzjbj	Capital (paid in by the state)	zgjyf	Employee Educational Expenses	bnyjzsz	Value Added Tax payable
gszch	Business Registration Number	jtzbj	Capital (paid in by collective owners)	pwf	Sewage Charges	bnjxse	Input VAT
		frzbj	Capital (paid in by the legal persons)	yywzc	Non-Operating Expenses	bnxxse	VAT on Sales
		grzbj	Capital (paid in by individuals)	yjkff	R&D Expenditure	zjtrhj	Intermediate Inputs
		gatzbj	Capital (paid in by owners in HK, Macau, and Taiwan)	lrze	Total Profits	jyxje	Operating Cash Flow
		wszbj	Capital (paid in by foreign owners)	cpxsrlr	Sales Profits	jyxjr	Operating Cash In-Flow
		cyrs	Total Employees	yylr	Operating Profits	jyxjc	Operating Cash Out-Flow
				qtywlr	Other Business Profits	txje	Investing Cash Flow
				qtlr	Other Profits	txjr	Investing Cash In-Flow
				ckjh	Exports	txjc	Investing Cash Out-Flow
				cqtz	Capital Expenditure	czxje	Financing Cash Flow
				dqtz	Long-Term Investment	czxjr	Financing Cash In-Flow
				bnzj	Depreciation of the year	czxjc	Financing Cash Out-Flow
				lsze	Total Interest Expenses and Tax		

Table OA.12: The List of 153 Universities in Our Sample.

Entitlement	University Name	Entitlement	University Name	Entitlement	University Name
Project 985	北京大学	Project 211	安徽大学	Project 211	南京师范大学
Project 985	北京航空航天大学	Project 211	北京工业大学	Project 211	内蒙古大学
Project 985	北京理工大学	Project 211	北京化工大学	Project 211	宁夏大学
Project 985	北京师范大学	Project 211	北京交通大学	Project 211	青海大学
Project 985	大连理工大学	Project 211	北京科技大学	Project 211	陕西师范大学
Project 985	电子科技大学	Project 211	北京林业大学	Project 211	上海财经大学
Project 985	东北大学	Project 211	北京体育大学	Project 211	上海大学
Project 985	东南大学	Project 211	北京外国语大学	Project 211	上海外国语大学
Project 985	复旦大学	Project 211	北京邮电大学	Project 211	石河子大学
Project 985	国防科技大学	Project 211	北京中医药大学	Project 211	四川农业大学
Project 985	哈尔滨工业大学	Project 211	大连海事大学	Project 211	苏州大学
Project 985	湖南大学	Project 211	第二军医大学	Project 211	太原理工大学
Project 985	华东师范大学	Project 211	第四军医大学	Project 211	天津医科大学
Project 985	华南理工大学	Project 211	东北林业大学	Project 211	武汉理工大学
Project 985	华中科技大学	Project 211	东北农业大学	Project 211	西安电子科技大学
Project 985	吉林大学	Project 211	东北师范大学	Project 211	西北大学
Project 985	兰州大学	Project 211	东华大学	Project 211	西藏大学
Project 985	南京大学	Project 211	对外经济贸易大学	Project 211	西南财经大学
Project 985	南开大学	Project 211	福州大学	Project 211	西南大学
Project 985	清华大学	Project 211	广西大学	Project 211	西南交通大学
Project 985	厦门大学	Project 211	贵州大学	Project 211	新疆大学
Project 985	山东大学	Project 211	哈尔滨工程大学	Project 211	延边大学
Project 985	上海交通大学	Project 211	海南大学	Project 211	云南大学
Project 985	四川大学	Project 211	合肥工业大学	Project 211	长安大学
Project 985	天津大学	Project 211	河北工业大学	Project 211	郑州大学
Project 985	同济大学	Project 211	河海大学	Project 211	中国传媒大学
Project 985	武汉大学	Project 211	湖南师范大学	Project 211	中国地质大学（北京）
Project 985	西安交通大学	Project 211	华北电力大学	Project 211	中国地质大学（武汉）
Project 985	西北工业大学	Project 211	华东理工大学	Project 211	中国矿业大学
Project 985	西北农林科技大学	Project 211	华南师范大学	Project 211	中国石油大学（北京）
Project 985	浙江大学	Project 211	华中农业大学	Project 211	中国石油大学（华东）
Project 985	中国海洋大学	Project 211	华中师范大学	Project 211	中国药科大学
Project 985	中国科学技术大学	Project 211	暨南大学	Project 211	中国政法大学
Project 985	中国农业大学	Project 211	江南大学	Project 211	中南财经政法大学
Project 985	中国人民大学	Project 211	辽宁大学	Project 211	中央财经大学
Project 985	中南大学	Project 211	南昌大学	Project 211	中央音乐学院
Project 985	中山大学	Project 211	南京航空航天大学	Institute	中国科学院
Project 985	中央民族大学	Project 211	南京理工大学	Institute	中国社会科学院
Project 985	重庆大学	Project 211	南京农业大学		

Table OA.13: The List of local USPs and national USPs.

University Name	Name of USP	Est. USP	National USP	Address
安徽大学	安徽大学国家大学科技园	1999	2021	合肥市蜀山区黄山路 602 号
北京大学	北大科技园(广州)	2011		广州市白云区北太路 1633 号
北京大学	北京北大科技园	1992	2002	北京市海淀区中关村北大街 127-1 号
北京大学	南京北大科技园科技发展	2017		南京市江宁区胜利路 99 号
北京大学	台州北大科技园	2017		浙江省台州市聚海大道 4298 号
北京大学	天津北大科技园	2014		天津市宝坻区西环北路与唐通公路交口 中关村科技城协同发展中心
北京大学	西安北大科技园	2016		西安曲江新区雁塔南路 292 号
北京大学	扬州北大科技园科技发展	2016		扬州市蜀冈—瘦西湖风景名胜区瘦西湖 路 195 号
北京大学	浙江北大科技园	2018		浙江省金华市婺城区八达路 66 号
北京工业大学	北京工业大学国家大学科技园	2000	2005	北京市大兴区地盛北街 1-31-2 号
北京工业大学	北京工业大学国家大学科技园 (金乡分园)	2020	2020	山东省济宁市金乡县诚信大道北
北京航空航天大学	北京航空航天大学国家大学科技园	2000	2003	北京市密云区兴源街 12 号
北京航空航天大学	洛阳北航科技园	2017		河南省洛阳市涧西区洛阳北航科技园
北京化工大学	北京化工大学国家大学科技园 (昌平园区)	2011	2011	北京市昌平区超前路 35 号
北京化工大学	北京化工大学国家大学科技园 (海淀园区)	2003	2004	北京市海淀区紫竹院路 98 号
北京化工大学	北京化工大学科技园(安庆分园)	2017		安徽省安庆市高新区皇冠路 8 号
北京交通大学	北京交通大学国家大学科技园	2001	2006	北京市海淀区高梁桥斜街 44 号
北京科技大学	北京科技大学国家大学科技园	2003	2005	北京市海淀区学院路 30 号
北京科技大学	北京科技大学烟台科技园	2018		山东省烟台市福山区长江路 300 号
北京理工大学	北京理工大学国家大学科技园	1992	2003	北京市海淀区西三环北路甲 2 号院
北京理工大学	北京理工大学中关村校区国防科技园	2010		北京市海淀区西三环北路甲 2 号院
北京理工大学	北京理工留学人员创业园	2003		北京市海淀区中关村南大街 9 号
北京林业大学	北京林业大学国家大学科技园	2009	2014	北京市海淀区清华东路 35 号
北京林业大学	渤海新区大学科技园	2014		沧州市黄骅市国营中捷农场新海路
北京师范大学	北京师范大学国家大学科技园	2001	2003	北京市海淀区学院南路 12 号
北京外国语大学	北京外国语大学科技园	2012		北京市海淀区紫竹院街道西三环北路 19 号
北京邮电大学	北京邮电大学国家大学科技园	1998	2003	北京市海淀区北太平庄街道西土城路 10 号
北京邮电大学	北京邮电大学国家大学科技园 (天津分园)	2010	2010	天津市津南区八里台镇丰泽四大道
北京中医药大学	京师药国家大学科技园	2002	2003	北京市海淀区学院南路 12 号

大连海事大学	大连海事大学科技园	2009		辽宁省大连市甘井子区黄浦路 523 号
大连理工大学	大连理工大学国家大学科技园	2004	2004	辽宁省大连市甘井子区软件园路 80 号
电子科技大学	电子科大科技园天府园	2001	2002	四川省成都市双流区华府大道四段双兴大道 1 号
东北大学	东北大学国家大学科技园	1990	2002	辽宁省沈阳市和平区三好街 11 号
东北林业大学	东北林业大学科技园	2017		南岗区哈双公路与王岗南大街交会处
东北农业大学	东北农业大学国家大学科技园	2011	2014	黑龙江省哈尔滨市香坊区木材街 59 号
东华大学	东华大学国家大学科技园	2000	2003	上海市长宁区金钟路 658 号
东南大学	东南大学国家大学科技园	1999	2002	江苏省南京市玄武区长江后街 6 号
福州大学	福州大学国家大学科技园	2014	2014	福建省福州市闽侯县学园路阳光楼
福州大学	福州大学国家大学科技园（晋江分园）	2021	2021	福建省泉州市晋江市水城路 1 号
复旦大学	复旦大学国家大学科技园	2000	2002	上海市杨浦区国泰路 11 号 1 号楼
广西大学	广西大学科技园	2006		广西壮族自治区南宁市西乡塘区高新二路 1 号
贵州大学	贵州大学国家大学科技园	2011	2014	贵州贵阳市花溪区花溪大道南段 2708 号
国防科技大学	岳麓山国家大学科技园	1999	2002	长沙市岳麓区潇湘中路 283 号
哈尔滨工程大学	哈尔滨工程大学国家大学科技园	2001	2003	黑龙江哈尔滨市南岗区邮政街 434 号
哈尔滨工程大学	哈尔滨工程大学青岛船舶科技园	2014		山东省青岛市黄岛区科教二路 167 号
哈尔滨工业大学	哈尔滨工业大学国家大学科技园	1999	2002	黑龙江哈尔滨市南岗区邮政街 434 号
合肥工业大学	合肥工业大学科技园	2008		合肥市包河区屯溪路合工大电子城
合肥工业大学	合肥国家大学科技园	1999	1999	安徽省合肥市蜀山区黄山路 602 号
河北工业大学	常州市国家大学科技园（河海大学常州校区分园）	2009	2009	江苏省常州市武进区三一路与天润大道交叉口
河北工业大学	河北工业大学国家大学科技园	2000	2006	石家庄桥西区新石北路 368 号
河北工业大学	河北工业大学国家大学科技园（沧州）园区	2012	2012	河北省沧州市运河区吉林北大道与兰州路交叉路口
河北工业大学	河北工业大学国家大学科技园（天津北辰）园区	2013	2013	天津市北辰区丁字沽一号路 8 号
河北工业大学	河北工业大学国家大学科技园（邢台）园区	2010	2010	邢台市中兴东大街辅路
湖南大学	湖南大学国家大学科技园	2006	2010	湖南省长沙市岳麓区谷苑路 186 号
湖南师范大学	岳麓山国家大学科技园	1999	2002	长沙市岳麓区潇湘中路 283 号
华北电力大学	华北电力大学国家大学科技园	2001	2006	北京市昌平区北农路 2 号
华北电力大学	华北电力大学国家大学科技园（保定分园）	2008	2008	河北省保定市竞秀区北二环 5699 号
华东理工大学	华东理工大学国家大学科技园	2003	2005	上海市金山区学府路 1300 号
华东师范大学	华东师范大学国家大学科技园	2001	2006	上海市普陀区金沙江路 155 号
华南理工大学	华南理工大学国家大学科技园	2000	2002	广东省广州市天河区五山路 373 之 3 号
华南师范大学	华南师大(广州)大学科技园	2019		广州市天河区中山大道西 55 号
华中科技大学	华中科技大学国家大学科技园	2000	2009	湖北省武汉市洪山区汤逊湖北路
华中农业大学	武汉东湖高新区国家大学科技园	2000	2002	湖北省武汉市江夏区汤逊湖北路 8 号

华中师范大学	华中师范大学国家大学科技园	2001	2021	湖北省武汉市东湖新技术开发区华师园路5号
吉林大学	吉林大学国家大学科技园	2000	2003	吉林省长春市朝阳区博才路168号
暨南大学	暨南大学科技园	2002		广州市天河区华景路35-37号
江南大学	江南大学国家大学科技园	2001	2006	江苏省无锡市滨湖区锦溪路99号
兰州大学	兰州大学国家大学科技园	2002	2002	兰州市东岗西路249号
辽宁大学	辽宁大学文化科技园	1999		辽宁省沈阳市皇姑区长江街128号
南昌大学	南昌大学国家大学科技园	2001	2004	江西省南昌市青山湖区高新大道589号
南京大学	南京大学科技园	2001	2002	南京市栖霞区元化路8号
南京航空航天大学	南京航空航天大学科技园	2021		江苏省南京市秦淮区御道街29号
南京理工大学	南京理工大学国家大学科技园	2001	2003	南京市秦淮区光华路街道光华路1号
南京理工大学	南京理工大学国家大学科技园 (栖霞园区)	2012	2012	江苏省南京市栖霞区纬地路
南京师范大学	南京师范大学科技园(栖霞园区)	2019		南京市栖霞区尧化街道科创路1号
南京师范大学	南京师范大学科技园(苏州园区)	2016		江苏省苏州市吴中区石湖西路188号
南京师范大学	南京师范大学科技园(玄武园区)	2021		江苏省南京市玄武区板仓街78号
南开大学	南开大学国家大学科技园	1999	1999	天津市南开区渭水道3号
南开大学	南开大学科技园	1999	2003	天津市南开区渭水道3号
内蒙古大学	内蒙古自治区国家大学科技园	2013	2013	内蒙古自治区呼和浩特市新城区科尔沁北路与成吉思汗东街交叉口
宁夏大学	宁夏大学国家大学科技园	1999	2010	宁夏回族自治区银川市金凤区宁夏大学
其他高校	深圳虚拟大学园国家大学科技园	2002	2003	深圳市南山区粤兴二道6号
青海大学	青海大学国家大学科技园	2004	2014	青海省西宁市城北区海湖大道延长段30号
清华大学	清华大学国家大学科技园	1993	2002	清华科技园地址是北京市海淀区中关村东路1号
清华大学	清华科技园(珠海)	2000		珠海市香洲区唐家湾镇唐家社区大学路101号
厦门大学	厦门大学国家大学科技园	1999	2005	福建省厦门市思明区龙虎山路36号
山东大学	山东大学国家大学科技园	2001	2002	山东省济南市市中区山东大学国家大学科技园
上海财经大学	上海财经大学国家大学科技园	2006	2009	上海市杨浦区纪念路8号
上海大学	上海大学国家大学科技园	1992	2003	上海市虹口区东江湾路188号
上海交通大学	上海交通大学国家大学科技园	2001	2002	上海市奉贤区奉浦大道1599
石河子大学	石河子兵团大学科技园	2004	2014	新疆维吾尔自治区石河子市北三东路19号
四川大学	四川大学国家大学科技园	1999	2002	四川省成都市武侯区一环路南一段24号
四川农业大学	四川农业大学科技园	2022		雅安市雨城区新康路46号
苏州大学	苏州大学国家大学科技园	2007	2010	江苏省苏州市吴中区星湖街328号
太原理工大学	太原理工大学科技园	2009	2009	山西省太原市万柏林区和平北路28号

天津大学	天津大学国家大学科技园	1999	2002	天津市静海区春曦道 11-1 号
同济大学	同济大学国家大学科技园	2003	2003	上海市杨浦区赤峰路 65 号
武汉大学	武汉大学国家大学科技园	1999	2010	武汉市江夏区佛祖岭街道大学园路 1 号
武汉理工大学	武汉理工大学科技园	2001	2021	湖北省武汉市江夏区大学园路 25 号 6 号
西安电子科技大学	西安电子科技大学国家大学科技园	2002	2006	陕西省西安市雁塔区科创路 168 号
西安交通大学	西安交通大学国家大学科技园	1996	2002	陕西省西安市雁塔区雁翔路 99 号
西北工业大学	西北工业大学国家大学科技园	2001	2002	西安市碑林区友谊西路 127 号
西北农林科技大学	西北农林科技大学国家大学科技园	2000	2002	咸阳市杨陵区李台街道杨凌示范区渭惠路 3 号
西南大学	重庆市北碚国家大学科技园	2004	2004	重庆市北碚区安礼路 128 号
西南交通大学	西南交通大学国家大学科技园	1994	2005	成都市金牛区交大路 144 号
新疆大学	新疆大学国家大学科技园	2001	2005	新疆维吾尔自治区乌鲁木齐市沙依巴克区西北路 458 号
延边大学	延边大学科技园	2014		吉林省延边朝鲜族自治州延吉市公园路 977 号
长安大学	长安大学科技园	2013		陕西省西安市未央区广运潭大道南段 4555 号
浙江大学	浙江大学国家大学科技园	2001	2002	浙江省杭州市西湖区西溪路 525 号
郑州大学	郑州大学大学科技园	2016	2006	河南省郑州市荥阳市学院路东区 16 号
中国传媒大学	中国传媒大学科技园	2009		北京市通州区新华东街 126 号
中国地质大学（武汉）	中国地质大学（武汉）科技园	2013		武汉市东湖新技术开发区佛祖岭一路 19 号
中国海洋大学	青岛国家大学科技园	2002	2010	青岛市城阳区上马街道汇智桥路 127 号
中国科学技术大学	合肥国家大学科技园	1999	2002	安徽省合肥市蜀山区黄山路 602 号
中国科学院	奥运村科技园	2007		北京市朝阳区北辰西路 1 号
中国科学院	山东中科科技园	2018		山东省济南市长清区卓成路与德彦街交叉口西北 60 米
中国科学院	中国科学院杭州科技园	2002		杭州高新开发区内学院路 50 号
中国科学院	中科（常州）创新科技园	2016		常州市钟楼区玉龙南路 179-2 号
中国矿业大学	中国矿业大学国家大学科技园	2006	2006	江苏省徐州市解放南路科技大厦
中国矿业大学	中国矿业大学国家大学科技园	2007	2010	海淀区学院路丁 11 号
中国农业大学	中国农业大学国家大学科技园	2006	2006	北京市海淀区天秀路与正黄旗西路交叉口
中国人民大学	中国人民大学国家大学科技园	2004	2008	北京市海淀区中关村大街甲 59
中国石油大学（北京）	中国石油大学科技园	2009		北京市昌平区振兴路 18 号
中国石油大学（华东）	中国石油大学（华东）大学科技园	2005	2005	山东省东营市东营区山东省东营市北二路
中国政法大学	中国政法大学科技园	2007		北京市海淀区西土城路 25 号
中南财经政法大学	中南财经政法大学科技园	2009		武昌区中南财经政法大学首义校区 29 号楼

中南大学	中南大学国家大学科技园	2003	2021	长沙市岳麓区岳麓街道溁左路中南大学校本部西侧
中山大学	中山大学国家大学科技园	2006	2006	广州市海珠区新港西路 135 号
中央财经大学	中央财经大学科技园	2006		北京市海淀区高粱桥 59 号
重庆大学	重庆大学国家大学科技园	2001	2002	重庆市沙坪坝区沙坪坝街道沙中路

Table OA.14: The List of Campuses of Our Sample Universities.

Panel A: Cites that effectively enter the sample of test

University Name	Name of Campus	Year of Establishment	Address
河海大学	河海大学常州校区	2000	江苏省常州市晋陵北路 200 号
华南师范大学	华南师范大学南海校区	2000	广东省佛山市南海区狮山镇南海软件科技园
浙江大学	浙江大学宁波理工学院	2001	浙江省宁波市鄞州区首南街道钱湖南路 1 号
福州大学	福州大学阳光学院	2001	福州经济技术开发区（马尾）卧龙山登龙路 99 号
贵州大学	贵州大学科技学院	2001	贵州省黔南布依族苗族自治州惠水县和平镇濠江大道
石河子大学	石河子大学商学院	2001	新疆五家渠市石河子大学五家渠校区
华北电力大学	华北电力大学科技学院	2002	河北省邢台市信都区泉南西大街 473 号
新疆大学	新疆大学科学技术学院	2002	新疆维吾尔自治区阿克苏市学府西路 1 号
清华大学	浙江清华长三角研究院	2003	浙江省嘉兴市亚太路 705 号 9 层
厦门大学	厦门大学嘉庚学院	2003	福建漳州招商局经济技术开发区厦门大学漳州校区
厦门大学	厦门大学漳州校区	2003	招商局漳州开发区南滨大道 300 号
南京师范大学	南京师范大学泰州学院	2004	江苏省泰州市海陵区济川东路 96 号
南京理工大学	南京理工大学泰州科技学院	2004	江苏省泰州市海陵区梅兰东路 8 号
西安电子科技大学	西安电子科技大学长安学院	2004	陕西省渭南市富平县职教园区
华北电力大学	华北电力大学保定校区	2005	河北省保定市北市区永华北大街 619 号
浙江大学	浙江大学台州研究院	2005	浙江省台州市市府大道西段 618 号
华中科技大学	华中科技大学温州先进制造技术研究院	2005	浙江省温州市瓯海区朝阳新街 225 号
南昌大学	南昌大学抚州校区	2005	江西省抚州市东临路 9 号
海南大学	海南大学三亚学院	2005	海南省三亚市吉阳区学院路 191 号
四川大学	四川大学锦江学院	2006	四川·彭山·锦江大道一号
西南财经大学	西南财经大学天府学院	2006	四川省德阳市罗江区大学北路 99 号
中国农业大学	中国农业大学烟台研究院	2007	山东省烟台市高新区滨海中路 2006 号
电子科技大学	电子科技大学广东电子信息工程研究院	2007	东莞市松山湖高新技术产业开发区总部二路 17 号
北京交通大学	北京交通大学沧州学院	2008	河北省黄骅市学院路 2009 号
河海大学	河海大学文天学院	2008	安徽省马鞍山市霍里山大道 333 号
北京大学	北京大学绍兴技术研究院	2008	浙江省绍兴市越城区群贤东路 2-1 号
上海财经大学	上海财经大学浙江学院	2008	浙江省金华市环城南路 99 号
河北工业大学	河北工业大学循环经济与新源发展研究院	2009	河北省唐山市曹妃甸区曹妃甸区工业区
中国石油大学（华东）	中国石油大学（华东）科学技术研究院	2009	山东省东营市东营区北一路 739 号
南京大学	南京大学盐城环保技术与工程研究院	2010	盐城市亭湖区环保大道环保科技城科技众创中心 D 座
合肥工业大学	合肥工业大学宣城研究院	2010	安徽省宣城市宣州区薰化路 698 号
天津大学	天津大学山东研究院	2010	淄博市鲁泰大道 51 号高分子材料创新园 B 座 404 室
海南大学	海南大学儋州校区	2010	海南省儋州市宝岛新村

Panel B: All Campuses of Our Sample Universities

University Name	Name of Campus	Est. Year	Address
安徽大学	安徽大学创新发展战略研究院	2016	合肥市肥西路3号安徽大学龙河校区
安徽大学	安徽大学创新发展战略研究院	2018	合肥市肥西路3号安徽大学龙河校区
安徽大学	安徽大学徽学与中国传统文化研究院	2006	合肥市肥西路3号问津楼
安徽大学	安徽大学集成电路先进材料与技术产教研融合研究院	2021	合肥市经开区九龙路111号安徽大学计算机科学与技术学院
安徽大学	安徽大学江淮学院	2003	史河校区合肥市蜀山区史河路8号
安徽大学	安徽大学经济与社会发展高等研究院	2014	合肥市肥西路3号安徽大学龙河校区
安徽大学	安徽大学绿色产业创新研究院	2019	合肥市高新区望江西路创业服务中心B座3楼
安徽大学	安徽大学龙河校区	1958	合肥市蜀山区肥西路3号
安徽大学	安徽大学磬苑校区	2003	安徽省合肥市九龙路111号
安徽大学	安徽大学物质科学与信息技术研究院	2017	合肥市经济技术开发区九龙路111号
安徽大学	安徽大学长三角一体化发展研究院	2020	合肥市肥西路3号安徽大学龙河校区
北京大学	北京大学文化传承与创新研究院（抚州）	2020	北京大学燕南园51号院、抚州市临川区梦湖东路(梦岛)
北京大学	北京大学	1898	北京市海淀区颐和园路5号
北京大学	北京大学包头研究院	2012	内蒙古包头装备制造产业园区北部新区北大科技园2号楼2楼
北京大学	北京大学海洋研究院	2013	北京大学廖凯原楼5层511
北京大学	北京大学邯郸创新研究院	2014	河北省邯郸市经济技术开发区中小企业加速器1-B
北京大学	北京大学南昌创新研究院	2019	江西省南昌市青山湖区高新艾溪湖北路269号高层次人才产业园14栋1-2层
北京大学	北京大学前沿交叉学科研究院	2006	北京大学静园1号院
北京大学	北京大学人文社会科学研究院	2016	北京市海淀区颐和园路5号北京大学静园二院
北京大学	北京大学绍兴技术研究院	2008	斗门镇袍江新区群贤东路2-1号(中兴大道与群贤路交叉口东南处)
北京大学	北京大学生物医学前沿创新中心	2010	北京市海淀区颐和园路5号, 北京大学生物医学前沿创新中心
北京大学	北京大学中国教育财政科学研究所	2005	北京大学教育学院大楼4层
北京大学	南京北大产业创新研究院	2012	南京经济技术开发区恒发路30-4号301室
北京工业大学	北京工业大学	1960	北京市朝阳区平乐园100号
北京工业大学	北京工业大学北京古月新材料研究院	2018	北京市朝阳区平乐园100号
北京工业大学	北京工业大学北京人工智能研究院	2020	北京市朝阳区平乐园100号北京工业大学理科楼8层
北京工业大学	北京工业大学北京智慧城市研究院	2014	北京市朝阳区平乐园100号
北京工业大学	北京工业大学耿丹学院	2005	北京市顺义区牛栏山镇牛富路牛山段3号
北京工业大学	北京工业大学激光工程研究院	1995	北京市朝阳区平乐园100号
北京工业大学	北京工业大学京津冀绿色发展研究院	2016	北京市朝阳区平乐园100号
北京工业大学	北京工业大学碳中和城市科技创新研究院	2021	北京市朝阳区平乐园100号
北京工业大学	北京工业大学循环经济研究院	2005	北京市朝阳区平乐园100号
北京航空航天大学	北京航空航天大学	1952	北京市海淀区学院路37号
北京航空航天大学	北京航空航天大学沙河校区	2010	北京市昌平区沙河高教园南三街9号

北京航空航天大学	北京航空航天大学中法工程师学院	2005	海淀区学院路 37 号
北京航空航天大学	国家科技资源共享服务工程技术研究中心	2013	北京市海淀区学院路 37 号
北京航空航天大学	首都高等教育发展研究基地	2005	北京市海淀区学院路 37 号
北京航空航天大学	卫星导航应用国家工程研究中心	2009	北京市海淀区学院路 37 号
北京航空航天大学	虚拟现实技术与系统国家重点实验室	2012	北京市海淀区学院路 37 号
北京化工大学	北化中国工业碳中和研究院	2021	北京市朝阳区北三环东路 15 号北京化工大学计算机楼 401
北京化工大学	北京化工大学	1958	北京市朝阳区北三环东路 15 号
北京化工大学	北京化工大学安庆研究院	2017	安徽省安庆市大观区环湖西路 8 号北京化工大学安庆研究院
北京化工大学	北京化工大学北方学院	2005	北京东燕郊国家高新技术产业开发区迎宾路 808 号
北京化工大学	北京化工大学昌平校区	2017	北京市昌平区南口镇南涧路 29 号
北京化工大学	北京化工大学常州先进材料研究院	2008	江苏常州常武中路 18 号常州科教城
北京化工大学	北京化工大学秦皇岛环渤海生物产业研究院	2014	秦皇岛市开发区数谷翔园 41 号楼
北京化工大学	北京化工大学厦门生物产业研究院	2012	福建省厦门市海沧区新园路 126 号
北京化工大学	北京化工大学苏州研究院	2010	江苏省苏州市相城区相城区澄阳路 3688 号
北京化工大学	北京化工大学西校区	1996	北京市海淀区紫竹院路 98 号
北京化工大学	中国化工产业发展研究院	2014	北京市朝阳区北三环东路 15 号
北京交通大学	北京交通大学	1896	北京市海淀区西直门外上园村 3 号
北京交通大学	北京交通大学北京综合交通发展研究院	2016	北京市丰台区六里桥南路首发大厦
北京交通大学	北京交通大学沧州学院（已转设）	2008	河北省黄骅市学院路 2009 号
北京交通大学	北京交通大学城市规划设计研究院	2021	北京市海淀区高梁桥斜街 28 号
北京交通大学	北京交通大学东校区	2000	北京市海淀区高梁桥斜街 44 号
北京交通大学	北京交通大学国家经济安全研究院	2018	北京市海淀区西直门外上园村 3 号北京交通大学 7 号办公楼
北京交通大学	北京交通大学国土空间与交通协同发展研究院	2021	北京市海淀区高梁桥斜街 28 号中安联合办公楼 5 层
北京交通大学	北京交通大学交通系统科学与工程研究院	2016	北京市海淀区上园村 3 号北京交大科技创新大厦 11 层
北京交通大学	北京交通大学深圳研究院	2002	深圳市南山区高新园南区虚拟大学园 A511 室
北京交通大学	北京交通大学唐山研究院	2019	河北省唐山市路南区新华西道 46 号
北京交通大学	北京交通大学威海校区	2015	威海市南海新区现代路 69 号
北京交通大学	北京交通大学威海研究院	2021	山东省威海市南海新区科研路 119 号 A07 楼
北京交通大学	北京交通大学长三角研究院	2012	江苏镇江市高新区南纬四路产业集聚区 C16 号楼
北京交通大学	北京交通大学长三角研究院（马鞍山）	2019	江苏镇江市高新区南纬四路产业集聚区 C16 号楼
北京科技大学	北京科技大学	1952	北京市海淀区学院路 30 号
北京科技大学	北京科技大学昌平创新园区	2018	北京市昌平区沙河镇昆仑路 12 号
北京科技大学	北京科技大学城镇化与城市安全研究院	2020	北京市海淀区学院路 30 号
北京科技大学	北京科技大学大安全科学研究院	2020	北京市海淀区学院路 30 号
北京科技大学	北京科技大学工程技术研究院	1996	北京市海淀区学院路 30 号

北京科技大学	北京科技大学管庄校区	1998	北京市朝阳区管庄北一里 19 号
北京科技大学	北京科技大学广州新材料研究院	2016	广州市海珠区桥头大街 228 号之五 2005
北京科技大学	北京科技大学科技史与文化遗产研究院	2014	北京市海淀区学院路 30 号
北京科技大学	北京科技大学人工智能研究院	2018	北京市海淀区学院路 30 号
北京科技大学	北京科技大学融合创新研究院	2016	北京市朝阳区管庄北一里北京科技大学管庄校区综合楼九层
北京科技大学	北京科技大学天津学院	2005	天津市宝坻区京津新城珠江北环东路 1 号
北京科技大学	北京科技大学新材料技术研究院	2008	北京市海淀区学院路 30 号腐蚀楼
北京理工大学	北京理工大学	1940	北京海淀区中关村南大街 5 号
北京理工大学	北京理工大学东南信息技术研究院	2019	福建省莆田市城厢区荔城中大道 1998 号市政南广场 1 号楼
北京理工大学	北京理工大学良乡校区	2002	北京市房山区良乡卫星城东
北京理工大学	北京理工大学深圳研究院	2014	深圳市南山区科技园南区虚拟大学园 A207 室深圳市南山区粤兴五道 9 号北理工创新大厦 403 室
北京理工大学	北京理工大学先进结构技术研究院	2015	北京海淀区中关村南大街 5 号
北京理工大学	北京理工大学珠海学院	2004	广东省珠海市高新区唐家湾镇金凤路 6 号
北京理工大学	中山市北京理工大学研究院	2009	广东省中山市祥兴路 6 号数贸大厦 1 栋 11 层
北京林业大学	北京林业大学	1952	北京市海淀区清华东路 35 号
北京林业大学	北京林业大学国家林草经贸研究院	2021	北京市海淀区清华东路 35 号
北京林业大学	北京林业大学黄河流域生态保护和高质量发展研究院	2019	北京市海淀区清华东路 35 号
北京林业大学	北京林业大学林草生态碳中和智慧感知研究院	2021	北京市海淀区清华东路 35 号
北京林业大学	北京林业大学生物质能源产业技术研究院	2021	北京市海淀区中关村南一条乙三号
北京林业大学	北京林业大学树木发育与基因编辑研究院	2021	清华东路 35 号北京林业大学实验楼
北京林业大学	北京林业大学文化与自然遗产研究院	2017	北京市海淀区清华东路 35 号
北京林业大学	北京林业大学圆明园研究院	2020	北京市海淀区清华东路 35 号
北京师范大学	北京师范大学	1902	北京市新街口外大街 19 号
北京师范大学	北京师范大学珠海分校	2001	广东省珠海市香洲区唐家湾镇金凤路 18 号
北京师范大学	北京师范大学珠海校区	2019	广东省珠海市香洲区唐家湾金凤路 18 号
北京体育大学	北京体育大学	1953	北京市海淀区信息路 48 号
北京体育大学	北京体育大学体育中外人文交流研究院	2020	北京市海淀区信息路 48 号
北京体育大学	北京体育大学中国体育战略研究院	2018	北京市海淀区信息路 48 号
北京体育大学	北京体育大学中国运动与健康研究院	2017	北京市海淀区信息路 48 号
北京外国语大学	北京外国语大学	1941	北京市海淀区西三环北路 2 号
北京外国语大学	北京外国语大学比较文明与人文交流高等研究院	2016	北京市海淀区西三环北路 2 号/19 号
北京外国语大学	北京外国语大学国际教育研究院	2017	北京市海淀区西三环北路 2 号/19 号
北京外国语大学	北京外国语大学国际中国文化研究院	1996	北京市海淀区西三环北路 2 号/19 号
北京外国语大学	北京外国语大学南方研究院	2015	佛山新城中欧中心 B 座

北京外国语大学	北京外国语大学区域与全球治理高等研究院	2017	北京市海淀区西三环北路 19 号北京外国语大学西校区国际大厦 913 室
北京外国语大学	北京外国语大学王佐良外国文学高等研究院	2016	北京市海淀区西三环北路 19 号北京外国语大学西院国际大厦 307 室
北京外国语大学	北京外国语大学许国璋语言高等研究院	2015	北京市海淀区西三环北路 2 号/19 号
北京外国语大学	北京外国语大学中华文化国际传播研究院	2021	北京市海淀区西三环北路 2 号/19 号
北京邮电大学	北京邮电大学	1955	北京市海淀区西土城路 10 号
北京邮电大学	北京邮电大学沙河校区（昌平校区）	2015	北京市西土城路 10 号
北京邮电大学	北京邮电大学深圳研究院	2016	深圳市高新区虚拟大学园
北京邮电大学	北京邮电大学世纪学院	2005	北京市延庆区康庄镇西官路
北京邮电大学	北京邮电大学无锡感知技术与产业研究院	2009	无锡新区太湖（国际）科技园
北京中医药大学	北京中医药大学	1956	北京市朝阳区北三环东路 11 号
北京中医药大学	北京中医药大学东方学院	2005	河北省廊坊市经济技术开发区东方大学城/沧州渤海新区中捷产业园区渤海 3 号路东段
北京中医药大学	北京中医药大学国际循证中医药研究院	2020	北京市朝阳区北三环东路 11 号
北京中医药大学	北京中医药大学国家中医药发展与战略研究院	2019	北京市朝阳区北三环东路 11 号
北京中医药大学	北京中医药大学国家中医药高等教育研究院	2019	北京市朝阳区北三环东路 11 号
北京中医药大学	北京中医药大学良乡校区	2015	北京市房山区良乡高教园区
北京中医药大学	北京中医药大学孙思邈研究院	2019	北院地址:铜川市王益区红旗街 68 号南院地址:铜川市新区长虹北路 26 号
北京中医药大学	北京中医药大学中医药文化研究院	2014	北京市朝阳区北三环东路 11 号
大连海事大学	大连东北亚国际航运中心研究院	2022	黄浦路 523 号科技金融大厦 A 座 10 层
大连海事大学	大连海事大学	1909	辽宁省大连市凌海路 1 号
大连海事大学	大连海事大学“一带一路”研究院	2016	大连市凌海路 1 号
大连海事大学	大连海事大学深圳研究院	2007	广东省深圳市南山区粤海街道高新南四道 19 号深圳虚拟大学园 A306
大连理工大学	大连理工大学	1949	辽宁省大连市甘井子区凌工路 2 号
大连理工大学	大连理工大学城市学院	2003	辽宁省大连市保税区生态核心区广宁路 1 号
大连理工大学	大连理工大学开发区校区	2004	大连经济技术开发区图强街 321 号
大连理工大学	大连理工大学盘锦校区	2012	辽宁省盘锦市辽东湾新区大工路 2 号
大连理工大学	大连理工大学深圳研究院	1999	深圳市宝安区隆昌路飞扬科技园
第二军医大学	第二军医大学	1949	上海市杨浦区翔殷路 800 号
第二军医大学	中国科学院-第二军医大学转化医学研究院	2012	上海市杨浦区翔殷路 800 号
第四军医大学	第四军医大学	1941	陕西省西安市长乐西路 169 号
电子科技大学	电子科技大学（深圳）高等研究院	2019	广东省深圳市龙华区观澜街道银星智界二期
电子科技大学	电子科技大学成都学院	2001	四川省成都市高新西区百叶路 1 号
电子科技大学	电子科技大学成都研究院	2012	成都市双流区华府大道四段 999 号
电子科技大学	电子科技大学电子科学技术研究院	2003	四川省成都市高新西区西源大道 2006 号

电子科技大学	电子科技大学广东电子信息工程研究院	2007	东莞市松山湖高新技术产业开发区总部二路17号
电子科技大学	电子科技大学九里堤校区	2001	成都市金牛区九里堤北路15号
电子科技大学	电子科技大学清水河校区	2007	成都市高新西区西源大道2006号
电子科技大学	电子科技大学研究生院宜宾分院	2018	宜宾临港经济技术开发区电子科技大学宜宾园区
电子科技大学	电子科技大学长三角研究院(湖州)	2020	浙江省湖州市西塞山路819号科技创新综合体B1幢
电子科技大学	电子科技大学长三角研究院(衢州)	2020	浙江省衢州市柯城区成电路1号
电子科技大学	电子科技大学重庆微电子产业技术研究院	2020	重庆市沙坪坝区西永微电园研发楼三期1号楼3单元
东北大学	朝阳东大矿冶研究院	2017	辽宁省朝阳市朝阳县朝阳柳城经济开发区
东北大学	东北大学	1923	辽宁省沈阳市和平区文化路三巷11号
东北大学	东北大学大连艺术学院	2003	辽宁省大连市金州区同汇路19号
东北大学	东北大学东软信息学院	2004	辽宁省大连市甘井子区软件园路8号
东北大学	东北大学浑南校区	2014	辽宁省沈阳市浑南区创新路195号
东北大学	东北大学无锡研究院	2012	无锡惠山职教园
东北林业大学	东北林业大学	1952	黑龙江省哈尔滨市香坊区和兴路26号
东北林业大学	东北林业大学林业人工智能研究院	2019	黑龙江哈尔滨市香坊区和兴路26号
东北林业大学	东北林业大学浦江工程技术研究院	2018	黑龙江哈尔滨市香坊区和兴路26号
东北林业大学	东北林业大学碳中和技术创新研究院	2021	黑龙江哈尔滨市香坊区和兴路26号
东北林业大学	东北林业大学自然保护地研究院	2019	黑龙江哈尔滨市香坊区和兴路26号
东北农业大学	东北农业大学	1948	中国哈尔滨香坊区长江路600号
东北农业大学	东北农业大学成栋学院	2002	松北校区:黑龙江省哈尔滨市利民开发区群英大街33号 哈南校区:黑龙江省哈尔滨市双城区崇文路9号
东北农业大学	哈尔滨市食品产业研究院	2015	哈尔滨市松北区创新一路2727号七楼
东北农业大学	黑龙江省绿色食品科学研究院	2013	黑龙江省哈尔滨市松北区科技创新城创新一路2727号
东北农业大学	新农村发展研究院	2012	中国哈尔滨长江路600号
东北师范大学	东北师范大学	1946	吉林省长春市南关区人民大街5268号
东北师范大学	东北师范大学净月校区	2000	长春市净月大街2555号
东北师范大学	东北师范大学人文学院(已转设)	2004	吉林省长春市净月高新技术产业开发区博硕路1488号
东北师范大学	东北师范大学深圳研究院	2020	深圳市坪山区坪山街道和兴路11号综合楼8楼
东北师范大学	东北师范大学中国东北研究院	2002	吉林省长春市净月大街2555号(东北师范大学净月校区)
东北师范大学	东北师范大学中国农村教育发展研究院	1999	吉林省长春市人民大街5268号
东华大学	东华大学环境艺术研究院	2003	上海市长宁区延安西路1882号东华大学三教18楼
东华大学	东华大学人工智能研究院	2020	上海市松江区人民北路2999号东华大学2号学院楼 2403室/长宁区延安西路1882号东华大学中心大楼中北383室
东华大学	东华大学绍兴创新研究院	2019	浙江省绍兴市柯桥区中国轻纺城跨境电商园区
东华大学	东华大学松江校区	2003	上海市松江区人民北路2999号
东华大学	东华大学研究院	2010	上海市松江区人民北路2999号 上海市延安西路1882号
东南大学	东南大学成贤学院	1998	江苏省南京市浦口区泰山街道东大路6号
东南大学	东南大学丁家桥校区	2000	江苏省南京市鼓楼区丁家桥87号(近湖南路)

东南大学	东南大学九龙湖校区	2006	南京市江宁区东南大学路2号
东南大学	东南大学-蒙纳士大学苏州联合研究生院	2012	江苏省苏州市独墅湖科教创新区林泉街377号公共学院7、8号楼
东南大学	东南大学四牌楼校区	1902	江苏省南京市玄武区四牌楼2号
东南大学	东南大学苏州校区	2018	江苏省苏州市苏州工业园区林泉街399号
东南大学	东南大学苏州研究院	2005	江苏苏州市苏州工业园区林泉街399号
对外经济贸易大学	对外经济贸易大学	1951	北京市朝阳区惠新东街10号
对外经济贸易大学	对外经济贸易大学北京对外开放研究院	2016	北京市朝阳区惠新东街10号对外经济贸易大学科研楼602室
对外经济贸易大学	对外经济贸易大学成都研究院	2019	四川省天府新区成都科学城新经济产业园D区1栋5层
对外经济贸易大学	对外经济贸易大学国家对外开放研究院	2017	北京市朝阳区惠新东街10号对外经济贸易大学科研楼602室
对外经济贸易大学	对外经济贸易大学海南研究院	2019	海南省海口市桂林洋高校区海南经贸职业技术学院图书馆214室
对外经济贸易大学	对外经济贸易大学青岛国际校区	2019	青岛西海岸新区张家楼镇与滨海街道办事处辖区交界处
对外经济贸易大学	对外经济贸易大学青岛研究院	2016	山东省青岛市市北区同安路67号
对外经济贸易大学	对外经济贸易大学区域国别研究院	2017	北京市朝阳区惠新东街10号对外经济贸易大学国际交流大厦B座二层
对外经济贸易大学	对外经济贸易大学全球创新与治理研究院	2021	北京市朝阳区惠新东街10号
对外经济贸易大学	对外经济贸易大学全球价值链研究院	2015	北京市朝阳区惠新东街10号
对外经济贸易大学	对外经济贸易大学深圳研究院	2013	广东省深圳市南山区高新南四道19号虚拟大学园A307
对外经济贸易大学	对外经济贸易大学中国世界贸易组织研究院	1991	北京市朝阳区惠新东街10号对外经济贸易大学逸夫科研楼5层
福州大学	福州大学集美校区	2006	福建省厦门市集美区理工路852号
福州大学	福州大学晋江校区	2015	中华人民共和国福建省晋江市金井镇
福州大学	福州大学旗山校区	2002	福州市闽侯大学城新区学园路2号
福州大学	福州大学泉港校区	2016	中国福建省福州市福州地区大学新区学园路2号
福州大学	福州大学数字媒体研究院	2008	工业路523号福州大学怡山校区科学楼10层
福州大学	福州大学铜盘校区	2020	福建省福州市福州大学城乌龙江北大道2号
福州大学	福州大学先进技术创新研究院	2019	福建省福州市福州大学城乌龙江北大道2号
福州大学	福州大学阳光学院(已转设)	2001	福州经济技术开发区(马尾)卧龙山登龙路99号
福州大学	福州大学至诚学院	2003	福建省·福州市鼓楼区杨桥西路50号
复旦大学	复旦大学大数据研究院	2015	上海市杨浦区邯郸路220号计算中心北楼2F-4F
复旦大学	复旦大学光电研究院	2021	上海市杨浦区淞沪路2005号复旦大学江湾校区交叉一号楼
复旦大学	复旦大学邯郸校区	1905	上海市杨浦区邯郸路220号
复旦大学	复旦大学江湾校区	2008	上海市淞沪路2005号
复旦大学	复旦大学脑科学研究院	2006	上海市医学院路138号明道楼
复旦大学	复旦大学上海视觉艺术学院	2005	上海市松江大学城文翔路2200号
复旦大学	复旦大学生物医学研究院	2005	上海市徐汇区医学院路138号科研二号楼

复旦大学	复旦大学芯片与系统前沿技术研究院	2020	上海市杨浦区淞沪路 2005 号复旦大学江湾校区一号交叉学科楼 B3020 室
复旦大学	复旦大学张江校区	2008	上海市张江高科技园区张衡路 825 号
广西大学	广西创新发展研究院	2016	广西南宁市西乡塘区大学东路 100 号
广西大学	广西大学	1928	广西南宁市大学东路 100 号
广西大学	广西大学巴马产教融合研究院	2020	广西南宁市西乡塘区大学东路 100 号
广西大学	广西大学农牧产业发展研究院	2019	广西南宁市大学路 100 号广西大学农牧产业发展研究院办公室
广西大学	广西大学新农村发展研究院	2013	广西大学君武楼 309
广西大学	广西大学行健文理学院（已转设）	2002	广西南宁市大学东路 176 号 广西南宁市邕武路 24 号
广西大学	广西大学智能研究院	2021	广西南宁市西乡塘区大学东路 100 号
广西大学	广西大学中国边疆经济研究院	2020	广西南宁市西乡塘区大学东路 100 号
广西大学	广西大学中国—东盟研究院	2005	广西南宁市西乡塘区大学东路 100 号
广西大学	中国（广西）自由贸易试验区研究院	2020	南宁市平乐大道 10 号中国—东盟经贸中心
贵州大学	贵州大学东盟研究院	2013	贵州省贵阳市花溪区贵州大学西校区明正楼
贵州大学	贵州大学贵阳研究院	2007	贵州省贵阳市花溪区
贵州大学	贵州大学花溪校区	2009	贵州省贵阳市花溪区
贵州大学	贵州大学科技学院（已转设）	2001	贵州省黔南布依族苗族自治州惠水县和平镇濠江大道
贵州大学	贵州大学明德学院（已转设）	2001	贵州省贵阳市贵安新区花溪大学城思雅路 8 号
贵州大学	贵州大学石斛研究院	2019	贵州省贵阳市花溪区
贵州大学	贵州大学新农村发展研究院	2014	贵州大学西校区崇德楼 2 楼 251 室
贵州大学	贵州大学循环经济研究院	2009	贵州省贵阳市花溪区
贵州大学	贵州大学长征文化研究院	2013	贵州省贵阳市花溪区贵州大学(北校区)逸夫楼东六楼
国防科技大学	国防科技大学	1953	湖南省长沙市开福区德雅路
国防科技大学	国防科技大学计算机研究所	1999	湖南省长沙市开福区德雅路
国防科技大学	国防科技大学战略研究所	2004	湖南省长沙市开福区德雅路
哈尔滨工程大学	哈尔滨工程大学	1953	黑龙江省哈尔滨市南岗区南通大街 145 号
哈尔滨工程大学	哈尔滨工程大学海洋先进材料研究院	2011	哈尔滨市南岗区南通大街 145 号
哈尔滨工程大学	哈尔滨工程大学核安全与先进核能研究院	2015	哈尔滨市南岗区南通大街 145 号哈尔滨工程大学 31 号楼
哈尔滨工程大学	哈尔滨工程大学南海研究院（三亚哈尔滨工程大学南海创新发展基地）	2020	三亚市崖州区崖州湾科技城百泰产业园四号楼四楼 A129 区
哈尔滨工程大学	哈尔滨工程大学青岛创新发展基地（青岛校区）	2016	山东省青岛市西海岸新区三沙路 1777 号
哈尔滨工程大学	哈尔滨工程大学人工智能研究院	2018	哈尔滨市南岗区南通大街 145 号
哈尔滨工程大学	烟台哈尔滨工程大学研究院	2018	山东省烟台经济技术开发区青岛大街 1 号
哈尔滨工业大学	哈尔滨工业大学	1920	黑龙江省哈尔滨市南岗区西大直街 92 号
哈尔滨工业大学	哈尔滨工业大学华德应用技术学院	1992	哈尔滨市松北区学院路 288 号
哈尔滨工业大学	哈尔滨工业大学深圳校区	2017	广东省深圳市南山区桃源街道深圳大学城哈尔滨工业大学校区
海南大学	海南大学儋州校区	2010	海南省儋州市宝岛新村
海南大学	海南大学海甸校区	1983	海南省海口市美兰区人民大道 58 号

海南大学	海南大学会计中外人文交流研究院	2020	海南省海口市美兰区人民大道 58 号
海南大学	海南大学三亚南繁研究院	2021	海南省三亚市崖州区还金路海南大学三亚南繁研究院
海南大学	海南大学三亚学院（已转设）	2005	海南省三亚市吉阳区学院路 191 号
海南大学	海南省公司治理研究院	2019	海南省海口市美兰区人民大道 58 号海南大学社科楼
海南大学	海南省开放型经济研究院	2019	海南省海口市美兰区人民大道 58 号
合肥工业大学	合肥工业大学	1945	安徽省合肥市屯溪路 193 号
合肥工业大学	合肥工业大学常州研究院	2009	天润大道天润科技大厦 c 座 6 层
合肥工业大学	合肥工业大学翡翠湖校区	2001	安徽省合肥市蜀山区丹霞路 485 号
合肥工业大学	合肥工业大学工业信息研究院	2011	安徽省合肥市蜀山区丹霞路 485 号
合肥工业大学	合肥工业大学工业与装备技术研究院	2013	安徽省合肥市屯溪路 193 号
合肥工业大学	合肥工业大学光电技术研究院	2002	安徽省合肥市屯溪路 193 号
合肥工业大学	合肥工业大学广东研究院	2014	佛山市三水工业园乐平西乐大道东 39 号登骏数码城二期厂房 B5 号
合肥工业大学	合肥工业大学六安路校区	1997	安徽省合肥市庐阳区六安路 269 号
合肥工业大学	合肥工业大学汽车工程技术研究院	2016	合肥市包河区花园大道互联网产业园 5 号楼
合肥工业大学	合肥工业大学深圳研究院	2000	深圳市南山区科技园南区虚拟大学园
合肥工业大学	合肥工业大学宣城校区	2011	安徽省宣城市宣州区薰化路 301 号
合肥工业大学	合肥工业大学宣城研究院	2010	安徽省宣城市宣州区薰化路 698 号
合肥工业大学	合肥工业大学智慧城市与智能建筑研究院	2020	合肥市包河区花园大道 369 号
合肥工业大学	合肥工业大学智能制造技术研究院	2014	合肥市包河区花园大道 369 号
河北工业大学	河北工业大学（张北）产业技术研究院	2019	张北县揽胜东路大数据展示中心大楼 505 室
河北工业大学	河北工业大学北辰校区	2004	天津市北辰区双口镇
河北工业大学	河北工业大学曹妃甸工业区循环经济与新能源发展研究院	2009	河北省唐山市曹妃甸区曹妃甸区工业区
河北工业大学	河北工业大学城市学院（已转设）	2001	天津市红桥区光荣道 29 号
河北工业大学	河北工业大学芬兰校区	2020	天津市红桥区光荣道 8 号
河北工业大学	河北工业大学冀南工业技术研究院（沙河市新材料与装备技术研究院）	2019	河北省沙河市经六路北段路东
河北工业大学	河北工业大学廊坊校区	1992	河北省廊坊市广阳区新华路 199 号
河北工业大学	河北工业大学数字经济产业研究院（石家庄）	2021	河北省石家庄高新区长江大道 315 号创新大厦 5 层 C/D 区
河北工业大学	河北省绿色化学工业产业技术研究院	2015	沧州市黄骅中捷产业园区
河北工业大学	雄安新区河北工业大学（安新）工业研究院	2020	河北省雄安新区安新县河北省保定市安新县安新镇保新公路 59 号 1 层 3 号
河北工业大学	张家口可再生能源产业技术研究院	2019	张家口市涿鹿县
河海大学	河海大学（山东）智能感知技术创新研究院	2021	山东省潍坊市寒亭区民主街阳光保险大厦 4 楼 401、402、403 室
河海大学	河海大学常州校区	2000	江苏省常州市晋陵北路 200 号
河海大学	河海大学淮安研究院	2013	淮安市经济技术开发区枚皋路 19 号智慧谷 A3 号楼 602 室
河海大学	河海大学江宁校区	2001	江苏省南京市佛城西路 8 号

河海大学	河海大学南通海洋与近海工程研究院	2011	南通市崇川路 58 号
河海大学	河海大学水科学研究院	2019	江苏省南京市江宁区佛城西路 189 号
河海大学	河海大学苏州研究院	2021	苏州市相城区荣泰街活力大厦
河海大学	河海大学宿迁研究院	2014	江苏省宿迁市经济技术开发区发展大道 901 号南楼
河海大学	河海大学文天学院（已转设）	2008	霍里山校区：安徽省马鞍山市霍里山大道 333 号 郑蒲港校区：安徽省马鞍山市郑蒲港新区河海中路 666 号
河海大学	江苏省河湖长制研究院	2021	南京市鼓楼区河海路河海大学
河海大学	水利部人力资源研究院	2011	南京市西康路 1 号河海大学闻天馆 7 楼
河海大学	长江保护与绿色发展研究院	2019	南京市鼓楼区河海路河海大学
湖南大学	湖南大学	1926	湖南省长沙市岳麓区麓山南路麓山门
湖南大学	湖南大学生命科学与技术研究院	2001	湖南长沙岳麓山
湖南大学	湖南大学无锡智能控制研究院	2021	江苏省无锡市高浪东路 999 号 D1 栋 6、7、8 层
湖南大学	湖南大学重庆研究院	2020	重庆渝北区龙兴镇际华南路 188 号 2-5
湖南师范大学	湖南师范大学南院校区	2019	湖南省长沙市岳麓区河西麓山南路
湖南师范大学	湖南师范大学树达学院	2001	湖南省长沙市岳麓区左家垅桃花坪 1 号
湖南师范大学	湖南师范大学桃花坪校区	2000	湖南省长沙市岳麓区左家垅桃花坪 1 号
湖南师范大学	湖南师范大学咸嘉湖校区	2002	湖南省长沙市桐梓坡路 371 号
湖南师范大学	湖南师范大学研学旅行研究院	2019	湖南省长沙市麓山路 36 号湖南师范大学中和楼
湖南师范大学	湖南师范大学语言与文化研究院	2018	湖南省长沙市岳麓区麓山中路中和楼 6 层
湖南师范大学	湖南师范大学张公岭校区	2001	湖南省长沙市芙蓉区纬六路
湖南师范大学	湖南师范大学中国乡村振兴研究院	2020	湖南省长沙市岳麓区麓山路 36 号湖南师范大学里仁楼
华北电力大学	华北电力大学保定校区	2005	河北省保定市北市区永华北大街 619 号
华北电力大学	华北电力大学国家能源发展战略研究院	2020	北京市昌平区北农路 2 号
华北电力大学	华北电力大学国家能源交通融合发展研究院	2018	北京市昌平区北农路 2 号
华北电力大学	华北电力大学科技学院（已转设）	2002	河北省邢台市信都区泉南西大街 473 号
华北电力大学	华北电力大学苏州研究院	2010	苏州工业园区独墅湖高等教育区林泉街 377 号公共学院 5 号楼 706 室
华北电力大学	华北电力大学先进材料研究院	2018	北京市昌平区北农路 2 号
华北电力大学	华北电力大学现代电力研究院	2006	北京市德胜门外朱辛庄华北电力大学现代电力研究
华北电力大学	华北电力大学新型能源系统与碳中和研究院	2021	北京市昌平区北农路 2 号
华东理工大学	华东理工大学常熟研究院	2010	上海市梅陇路 130 号
华东理工大学	华东理工大学奉贤校区	2007	上海市奉贤区海思路 999 号
华东理工大学	华东理工大学南通研究院	2014	上海市梅陇路 130 号
华东理工大学	华东理工大学苏州工业技术研究院	2014	江苏省苏州市高新区科灵路 78 号苏高新软件园 4 号楼
华东理工大学	华东理工大学徐汇校区	1952	上海市徐汇区梅陇路 130 号
华东师范大学	华东师范大学闵行校区	2006	上海市东川路 500 号
华东师范大学	华东师范大学普陀校区	1951	上海市中山北路 3663 号
华东师范大学	华东师范大学重庆研究院	2019	重庆市重庆市渝北区卉竹路 2 号

华南理工大学	华南理工大学大学城校区	2004	广州大学城外环东路 382 号华南理工大学
华南理工大学	华南理工大学广州国际校区	2021	广东省广州市番禺区兴业大道东 777 号
华南理工大学	华南理工大学广州汽车学院	2005	广东省广州市花都区学府路一号
华南理工大学	华南理工大学五山校区	1918	广州市天河区五山路 381 号
华南师范大学	华南农业大学量子物质研究院	2018	广东省广州市番禺区广州大学城外环西路 378 号
华南师范大学	华南师范大学(清远)科技创新研究院	2018	广东省清远市清城区高新技术产业开发区创兴大道 18 号天安智谷科技产业园总部楼 F03
华南师范大学	华南师范大学半导体科学技术研究院	2019	广东省佛山市南海区狮山镇华南师范大学南海校区
华南师范大学	华南师范大学北斗研究院	2021	广东省佛山市南海区狮山镇华南师范大学南海校区
华南师范大学	华南师范大学大学城校区	2003	广东省广州市番禺区广州大学城外环西路 378 号
华南师范大学	华南师范大学华南先进光电子研究院	2012	广州大学城华南师范大学理五栋(大学城西五路)
华南师范大学	华南师范大学环境研究院	2018	广东省广州市番禺区广州大学城外环西路 378 号
华南师范大学	华南师范大学南海校区	2000	广东省佛山市南海区狮山镇南海软件科技园
华南师范大学	华南师范大学脑科学与康复医学研究院	2015	广东省广州市天河区中山大道西 55 号
华南师范大学	华南师范大学人文社会科学高等研究院	2018	华南师范大学高校教师村 AB 栋二楼
华南师范大学	华南师范大学汕尾校区	2021	广东省汕尾市城区香江大道西 55 号
华南师范大学	华南师范大学石牌校区	1933	广东省广州市天河区中山大道西 55 号
华南师范大学	华南师范大学增城学院(已转设)	1998	广东省广州市黄埔区九龙大道 206 号
华中科技大学	华中科技大学	1952	湖北省武汉市洪山区珞喻路 1037 号
华中科技大学	华中科技大学国际医学中心	2021	湖北省武汉市群英路 66 号
华中科技大学	华中科技大学温州先进制造技术研究院	2005	浙江省温州市瓯海区朝阳新街 225 号
华中科技大学	华中科技大学文华学院	2003	湖北省武汉市东湖高新技术开发区文华园路 8 号
华中科技大学	华中科技大学武昌分校	2000	湖北省武汉市洪山区南李路 22 号
华中科技大学	深圳华中科技大学研究院	2000	深圳市南山区粤兴三道 9 号
华中农业大学	华中农业大学	1898	湖北省武汉市洪山区狮子山街 1 号
华中农业大学	华中农业大学楚天学院(已转设)	2004	湖北省武汉市江夏区藏龙岛杨桥湖大道 1 号
华中农业大学	华中农业大学宏观农业研究院	2018	湖北省武汉市洪山区狮子山街 1 号华中农业大学主楼
华中农业大学	华中农业大学湖北生态文明建设研究院	2015	湖北·武汉南湖狮子山街一号
华中农业大学	华中农业大学双水双绿研究院	2018	武汉市洪山区狮子山街 1 号
华中农业大学	华中农业大学新农村发展研究院	2009	湖北·武汉南湖狮子山街一号
华中师范大学	华中师范大学	1903	湖北省武汉市洪山区珞喻路 152 号
华中师范大学	华中师范大学北京研究院	2014	湖北省武汉市洪山区珞喻路 152 号
华中师范大学	华中师范大学汉口分校(已转设)	2000	湖北省武汉市江夏区文化大道 299 号
华中师范大学	华中师范大学梁子湖校区(建设中)	2015	湖北省武汉市洪山区珞喻路 152 号华中师范大学梁子湖校区
华中师范大学	华中师范大学南湖校区	2018	湖北省武汉市洪山区雄楚大道 382 号
华中师范大学	华中师范大学深圳研究院	2019	深圳市南山区粤海街道高新南四道 19 号 R4 大楼
华中师范大学	华中师范大学武汉传媒学院(已转设)	2004	湖北省武汉市江夏区藏龙岛凤凰大道 2 号
华中师范大学	华中师范大学粤港澳大湾区教育研究院	2021	深圳市南山区粤海街道高新南四道 19 号 R4 大楼
华中师范大学	华中师范大学中国旅游研究院武汉分院	2010	湖北省武汉市珞喻路 152 号华中师范大学 10 号教学楼南楼 318 办公室
吉林大学	吉林大学朝阳校区	2000	吉林省长春市朝阳区西民主大街 938 号
吉林大学	吉林大学和平校区	2004	吉林省长春市西安大路 5333 号

吉林大学	吉林大学南湖校区	2001	长春市南湖大路 5372 号
吉林大学	吉林大学南岭校区	2000	吉林省长春市人民大街 5988 号
吉林大学	吉林大学青岛汽车研究院	2015	青岛市李沧区楼山路 1 号
吉林大学	吉林大学新民校区	2000	长春市新民大街 828 号
吉林大学	吉林大学重庆研究院	2020	重庆市渝北区互联网学院 1 号楼 308
吉林大学	吉林大学珠海学院	2004	广东省珠海市金湾区安基东路 8 号
暨南大学	暨南大学“一带一路”与粤港澳大湾区研究院	2019	广州市黄埔大道西 601 号
暨南大学	暨南大学 21 世纪丝绸之路研究院	2014	广州市黄埔大道西 601 号
暨南大学	暨南大学病原微生物研究院	2017	广东省广州市黄埔大道西 601 号暨南大学梁仲景楼 7 楼
暨南大学	暨南大学产业经济研究院	2006	广州市黄埔大道西 601 号暨南大学产业经济研究院
暨南大学	暨南大学地下水与地球科学研究院	2016	广州市黄埔大道西 601 号
暨南大学	暨南大学低碳与可持续发展研究院	2020	广州市黄埔大道西 601 号暨南大学中惠楼 501
暨南大学	暨南大学东莞研究院	2013	东莞市松山湖园区学府路 1 号 10 栋 3 楼 301 室
暨南大学	暨南大学番禺校区	2012	广东省广州市番禺区兴业大道东 855 号
暨南大学	暨南大学佛教文化研究院	2013	广州市黄埔大道西 601 号暨南大学文学院
暨南大学	暨南大学光子技术研究院	2015	广东省广州市兴业大道东 855 号暨南大学番禺校区学院楼 B4 栋
暨南大学	暨南大学广东智慧教育研究院	2021	广州市天河区石牌华南师范大学科技实验楼 2 层
暨南大学	暨南大学轨道交通研究院	2013	广州市黄埔大道西 601 号
暨南大学	暨南大学华侨华人研究院	2011	广州市黄埔大道西 601 号
暨南大学	暨南大学华文教育研究院	2012	广州市天河区瘦狗岭路 377 号暨南大学华文学院
暨南大学	暨南大学华文校区	1993	广州市天河区瘦狗岭路 377 号
暨南大学	暨南大学环境与气候研究院	2016	广州市番禺区兴业大道东 855 号祈福楼 B1 栋
暨南大学	暨南大学机器人智能技术研究院	2016	广州市黄埔大道西 601 号
暨南大学	暨南大学建筑设计研究院	1992	广州市黄埔大道西 601 号
暨南大学	暨南大学经济与社会研究院	2015	广州市黄埔大道西 601 号
暨南大学	暨南大学临床医学研究院	2014	广州市黄埔大道西 601 号
暨南大学	暨南大学纳米光子学研究院	2016	广州市番禺区兴业大道东 855 号
暨南大学	暨南大学南方传媒研究院	2012	广州市黄埔大道西 601 号文科楼、第二文科楼
暨南大学	暨南大学全球青年领导力研究院	2020	广州市黄埔大道西 601 号
暨南大学	暨南大学韶关研究院	2011	东莞（韶关）产业转移工业园高新技术创业服务中心三楼主楼
暨南大学	暨南大学深圳校区	1996	深圳市南山区华侨城生态广场东街 6 号
暨南大学	暨南大学生命与健康工程研究院	2005	广州市黄埔大道西 601 号
暨南大学	暨南大学生物医学转化研究院	2013	广州市黄埔大道西 601 号暨南大学北门梁仲景楼 8、9 楼，生物医学转化研究院
暨南大学	暨南大学石牌校区	1906	广东省广州市天河区黄埔大道西 601 号
暨南大学	暨南大学衰老与再生医学研究院	2016	广州市黄埔大道西 601 号
暨南大学	暨南大学文化遗产创意产业研究院	2017	广州市黄埔大道西 601 号
暨南大学	暨南大学物联网与物流工程研究院	2015	广州市黄埔大道西 601 号
暨南大学	暨南大学先进耐磨蚀及功能材料研究院	2016	广州市黄埔大道西 601 号
暨南大学	暨南大学先进与应用化学合成研究院	2018	广州市黄埔大道西 601 号

暨南大学	暨南大学新能源技术研究院	2016	广州市番禺区兴业大道东 855 号暨南大学
暨南大学	暨南大学一国两制与基本法研究院	2020	广东省广州市天河区黄埔大道西 601 号暨南大学第二文科楼
暨南大学	暨南大学粤港澳中枢神经再生研究院	2012	广州市黄埔大道西 601 号暨南大学粤港澳中枢神经再生研究院
暨南大学	暨南大学珠海校区	1998	广东省珠海市香洲区前山路 206 号
江南大学	白马未来食品研究院	2020	南京市溧水区白马大道 111 号
江南大学	国家农产品加工研究院	2006	江苏省无锡市蠡湖大道 1800 号
江南大学	江南大学	1902	江苏省无锡市蠡湖大道 1800 号
江南大学	江南大学（宿迁）产业技术研究院	2012	江苏省无锡市蠡湖大道 1800 号
江南大学	江南大学开放创新设计研究院	2013	无锡（国家）工业设计园
江南大学	江南大学蠡湖校区	2005	无锡市滨湖区蠡湖大道 1800 号
江南大学	江南大学太湖学院（已转设）	2002	江苏省无锡市钱荣路 68 号
江南大学	江南大学先进技术研究院	2021	江苏省无锡市蠡湖大道 1800 号
江南大学	江南大学新农村发展研究院	2013	江苏省无锡市蠡湖大道 1800 号
江南大学	江南大学遵义研究院	2021	中国贵州省遵义市仁怀市鲁班大道
兰州大学	兰州大学城关校区	1909	兰州市城关区天水南路 222 号
兰州大学	兰州大学隆基未来技术研究院	2021	兰州市天水南路 222 号
兰州大学	兰州大学榆中校区	2001	兰州市榆中县夏官营镇吴谢营社
辽宁大学	辽宁大学（阜新）城市研究院	2022	沈阳市皇姑区崇山中路 66 号
辽宁大学	辽宁大学（营口）城市研究院	2017	沈阳市皇姑区崇山中路 66 号
辽宁大学	辽宁大学崇山校区	1948	沈阳市皇姑区崇山中路 66 号
辽宁大学	辽宁大学李安民经济研究院	2017	沈阳市崇山中路 66 号
辽宁大学	辽宁大学蒲河校区	2004	辽宁省沈阳市皇姑区崇山中路 66 号
辽宁大学	辽宁大学武圣校区	1997	辽宁省沈阳市沈北新区道义南大街 58 号（沈阳校区） 辽宁省辽阳市白塔区青年大街 38 号（武圣校区）
辽宁大学	辽宁大学现代化经济体系研究院	2017	沈阳市皇姑区崇山中路 66 号
南昌大学	江西省区域经济研究院	2010	江西省南昌市红谷滩区学府大道 999 号智华经管楼
南昌大学	南昌大学东湖校区	2005	南昌市东湖区八一大道 461 号
南昌大学	南昌大学抚州校区	2005	江西省抚州市东临路 9 号
南昌大学	南昌大学高等研究院	2007	江西省南昌市红谷滩区学府大道 999 号高等研究院
南昌大学	南昌大学共青学院	1993	共青城市南湖大道 465 号
南昌大学	南昌大学光伏研究院	2014	江西省南昌市红谷滩区学府大道 999 号
南昌大学	南昌大学国学研究院	2009	江西省南昌市红谷滩区学府大道 999 号
南昌大学	南昌大学江西发展研究院	2015	江西省南昌市红谷滩新区学府大道 999 号南昌大学前湖校区行政楼 3 楼
南昌大学	南昌大学教育发展研究院	2003	江西省南昌市红谷滩区学府大道 999 号南大前湖校区人文楼五楼
南昌大学	南昌大学军工研究院	2006	江西省南昌市红谷滩区学府大道 999 号
南昌大学	南昌大学科学技术学院	2001	江西省九江共青城市五四大道 199 号
南昌大学	南昌大学空间科学与技术研究院	2010	江西省南昌市红谷滩区学府大道 999 号
南昌大学	南昌大学锂电及新能源汽车研究院	2011	江西省南昌市红谷滩区学府大道 999 号
南昌大学	南昌大学绿色建筑技术研究院	2012	江西省南昌市红谷滩区学府大道 999 号

南昌大学	南昌大学鄱阳湖校区	1993	江西省共青城市南湖大道 50 号
南昌大学	南昌大学前湖校区	2002	中国江西省南昌市新建县
南昌大学	南昌大学生命科学研究院	2010	江西省南昌市红谷滩区学府大道 999 号
南昌大学	南昌大学四方艺术研究院	2010	江西省南昌市红谷滩区学府大道 999 号
南昌大学	南昌大学文化资源与产业研究院	2010	江西省南昌市红谷滩区学府大道 999 号
南昌大学	南昌大学中国乡村振兴研究院	2016	江西省南昌市红谷滩区学府大道 999 号
南昌大学	南昌大学转化医学研究院	2010	江西省南昌市红谷滩区学府大道 999 号
南京大学	常州南京大学高新技术研究院	2006	常州科教城天润大道南大常州研究院
南京大学	马鞍山南大高新技术研究院	2013	南京市栖霞区元化路 8 号南大科学园国家双创示范基地 2 号楼 3 楼
南京大学	南京大学（苏州）高新技术研究院	2009	苏州工业园区仁爱路 150 号
南京大学	南京大学常熟生态研究院	2012	常熟市南湖湿地公园风景区（苏虞张公路西侧）
南京大学	南京大学鼓楼校区	1952	南京市鼓楼区汉口路 22 号
南京大学	南京大学金陵学院	1998	江苏省南京市浦口区学府路 8 号
南京大学	南京大学昆山创新研究院	2011	江苏省昆山市祖冲之南路 1699 号综合大楼 8 楼
南京大学	南京大学浦口校区	1993	江苏省南京市浦口区学府路 8 号
南京大学	南京大学苏州校区	2022	江苏省苏州市虎丘区太湖大道绿岛花园西南侧、江苏省苏州市虎丘区太湖大道
南京大学	南京大学仙林校区	2009	江苏省南京市仙林大道 163 号
南京大学	南京大学盐城环保技术与工程研究院	2010	盐城市亭湖区环保大道环保科技城科技众创中心 D 座
南京大学	泉州南京大学环保产业研究院	2018	泉州市丰泽区北峰街道泉州软件园研发 2 号楼
南京大学	深圳南大研究院	2005	深圳市南山区科技园南区粤兴三道 6 号南大产学研大厦
南京航空航天大学	南京航空航天大学国际前沿科学研究院	2021	江苏省南京市秦淮区御道街 29 号
南京航空航天大学	南京航空航天大学将军路校区	1999	江苏省南京市江宁区将军大道 29 号
南京航空航天大学	南京航空航天大学金城学院	1999	南京市江宁区禄口街道航金大道 88 号
南京航空航天大学	南京航空航天大学明故宫校区	1952	江苏省南京市秦淮区御道街 29 号
南京航空航天大学	南京航空航天大学天目湖校区	2019	江苏省溧阳市滨河东路 29 号
南京航空航天大学	南京航空航天大学无人机研究院	2000	南京市秦淮区李府街 8 号无人机研究院
南京航空航天大学	南京航空航天大学综合能源研究院	2020	江苏省南京市秦淮区御道街 29 号
南京理工大学	南京理工大学	1953	江苏省南京市玄武区孝陵卫街道孝陵卫街 200 号
南京理工大学	南京理工大学北方研究院	2015	天津市河西区怒江路 8 号
南京理工大学	南京理工大学常熟研究院	2010	常熟经济技术开发区科创园研究院路 5 号
南京理工大学	南京理工大学工程技术研究院	2012	南京市麒麟科技创新园智汇路 300 号 B 单元二楼
南京理工大学	南京理工大学工业互联网研究院	2020	江苏省江阴市福星路 8 号
南京理工大学	南京理工大学江阴校区	2020	江苏省无锡市江阴市滨江西路 599 号
南京理工大学	南京理工大学连云港研究院	2011	连云港市科教创业园区晨光路 2 号
南京理工大学	南京理工大学人工智能研究院	2018	江苏省南京市孝陵卫街 200 号
南京理工大学	南京理工大学泰州科技学院	2004	江苏省泰州市海陵区梅兰东路 8 号
南京理工大学	南京理工大学无锡研究院	2009	国家级锡山经济技术开发区
南京理工大学	南京理工大学紫金学院	1999	江苏省南京市栖霞区文澜路 89 号
南京理工大学	南京理工大学自动化研究院	2013	南京麒麟人工智能产业园 A1 号楼
南京农业大学	南京农业大学城乡规划设计研究院	2004	南京市卫岗 1 号
南京农业大学	南京农业大学海洋科学研究院	2012	南京市卫岗 1 号

南京农业大学	南京农业大学金善宝农业现代化研究院	2015	南京市卫岗1号
南京农业大学	南京农业大学浦口校区	2020	江苏省南京市浦口区点将台路40号
南京农业大学	南京农业大学乾宝湖羊产业研究院	2019	南京市卫岗1号
南京农业大学	南京农业大学区域农业研究院	2016	南京市卫岗1号
南京农业大学	南京农业大学数字乡村发展与工程研究院	2009	南京市卫岗1号
南京农业大学	南京农业大学卫岗校区	1902	江苏省南京市卫岗1号
南京农业大学	南京农业大学智慧农业研究院	2018	南京市卫岗1号
南京农业大学	南京农业大学中国国土资源与生态文明建设研究院	2013	南京市卫岗1号
南京农业大学	南京农业大学中国新农村建设研究院	2006	南京市卫岗1号
南京农业大学	南京农业大学中国资源环境与发展研究院	2020	南京市卫岗1号
南京农业大学	南京农业大学中华农业文明研究院	2014	南京市卫岗1号
南京农业大学	南京农业大学自然资源与国家发展研究院	2004	南京市卫岗1号
南京师范大学	南京师范大学(六合)农业发展研究院	2013	南京市仙林大学城文苑路1号
南京师范大学	南京师范大学常熟发展研究院	2009	南京市仙林大学城文苑路1号
南京师范大学	南京师范大学常州创新发展研究院	2016	江苏省常州市太湖西路7号 江苏省常州市通江南路299号
南京师范大学	南京师范大学创新经济研究院	2009	中国江苏省南京市鼓楼区宁海路122号
南京师范大学	南京师范大学江苏法治发展研究院	2007	中国江苏省南京市鼓楼区广州路
南京师范大学	南京师范大学苏州智慧创意研究院	2013	苏州市吴中区胥口镇胥市街550号
南京师范大学	南京师范大学泰州学院	2004	江苏省泰州市海陵区济川东路96号
南京师范大学	南京师范大学仙林校区	1999	中国江苏省南京市栖霞区文苑路1号
南京师范大学	南京师范大学镇江创新发展研究院	2017	镇江市南徐大道298号A座高新大厦10楼
南京师范大学	南京师范大学中北学院	1999	丹阳市正德路8号
南京师范大学	南京师范大学中国法治现代化研究院	2015	中国江苏省南京市鼓楼区宁海路122号
南京师范大学	南京师范大学紫金校区	2000	中国江苏省南京市玄武区板仓街78号
南开大学	格拉斯哥大学-南开大学联合研究生院	2014	天津市卫津路94号
南开大学	南开大学滨海学院	2004	天津市滨海新区大港街学院路634号
南开大学	南开大学云南研究院	2003	云南省昆明市五华区云南师范大学121校区田家炳教育书院610(国立西南联大旧址旁)
内蒙古大学	创业学院	2008	内蒙古自治区呼和浩特市玉泉区昭君路24号
内蒙古大学	内蒙古大学北校区	1957	呼和浩特市赛罕区大学西街235号
内蒙古大学	内蒙古大学南校区	2008	内蒙古呼和浩特市玉泉区昭君路24号
内蒙古大学	内蒙古大学设计研究院	2013	内蒙古呼和浩特市玉泉区昭君路24号
宁夏大学	宁夏大学贺兰山校区	1958	宁夏银川市西夏区贺兰山西路489号
宁夏大学	宁夏大学教育研究院	2014	宁夏银川市西夏区贺兰山西路489号
宁夏大学	宁夏大学民族学与文化旅游产业研究院	2019	宁夏回族自治区银川市西夏区文萃北街217号
宁夏大学	宁夏大学西夏学研究院	1991	中国·宁夏·银川·西夏区文萃北街217号
宁夏大学	宁夏大学中卫校区	2014	宁夏回族自治区中卫市沙坡头区
宁夏大学	新华学院	2002	银川市西夏区贺兰山西路686号

青海大学	昆仑学院	2004	青海省西宁市宁张路 175 号
青海大学	青海大学	1958	青海省西宁市宁大路 251 号
青海大学	青海大学产业发展研究院	2011	青海大学行政 B 楼三楼
青海大学	青海大学-清华大学三江源研究院	2010	青海省西宁市宁大路 251 号
青海大学	青海大学新农村发展研究院	2013	青海大学新农村发展研究院
清华大学	东莞深圳清华大学研究院创新中心	2013	东莞松山湖国际创新创业社区 G1 栋
清华大学	河北清华发展研究院	2002	北京市清华大学 6 号院（寓园教工餐厅东侧）
清华大学	清华大学	1911	北京市海淀区双清路 30 号
清华大学	清华大学合肥公共安全研究院	2016	安徽省合肥市经开区习友路 5999 号
清华大学	清华大学天津高端装备研究院	2014	天津市东丽区华明高新区弘顺道科创慧谷园区 4 号楼、5 号楼
清华大学	清华大学无锡应用技术研究院	2012	江苏省无锡市滨湖区建筑西路 777 号 A3 幢
清华大学	清华海峡研究院	2015	厦门市湖里区岐山北路 520 号艾德航空工业园二期 C 座 9 层
清华大学	清华四川能源互联网研究院	2016	成都市天府新区天府菁蓉中心 A 区 5 号楼
清华大学	清华苏州环境创新研究院	2015	江苏省苏州高新区光启路 100 号
清华大学	清华珠三角研究院	2015	广州市黄埔区香雪八路 98 号香雪国际公寓 F 栋
清华大学	深圳清华大学研究院	1996	深圳高新技术产业园深圳清华大学研究院 A402 室
清华大学	浙江清华长三角研究院	2003	浙江省嘉兴市亚太路 705 号 9 层
厦门大学	厦门大学嘉庚学院	2003	福建漳州招商局经济技术开发区厦门大学漳州校区
厦门大学	厦门大学深圳研究院	2000	深圳市南山区高新南四道 19 号虚拟大学园 R4-A600
厦门大学	厦门大学思明校区	1921	福建省厦门市思明区思明南路 422 号
厦门大学	厦门大学台湾研究院	2004	中国福建省厦门市思明南路 422 号台湾研究院
厦门大学	厦门大学翔安校区	2012	福建省厦门市翔安区新店镇翔安南路 4221 号
厦门大学	厦门大学漳州校区	2003	招商局漳州开发区南滨大道 300 号
山东大学	山东大学	1901	山东省济南市山大南路 27 号
山东大学	山东大学趵突泉校区	2000	山东省济南市文化西路 44 号
山东大学	山东大学软件园校区	2001	济南高新区舜华路 1500 号
山东大学	山东大学深圳研究院	2011	深圳市南山区高新南四道 19 号虚拟大学园 A301-304
陕西师范大学	陕西教师发展研究院	2021	西安市雁塔区长安南路 199 号陕西师范大学雁塔校区教学一楼
陕西师范大学	陕西师范大学雁塔校区	1944	西安市雁塔区长安南路 199 号
陕西师范大学	陕西师范大学长安校区	2002	西安市长安区西长安街 620 号
陕西师范大学	陕西师范大学中国西部边疆研究院	2013	中国·西安市长安南路 199 号
上海财经大学	上海财经大学	1917	上海市国定路 777 号
上海财经大学	上海财经大学高等研究院	2006	上海市国定路 777 号
上海财经大学	上海财经大学公共政策与治理研究院	2013	上海市杨浦区武川路 111 号上海财经大学武川路校区
上海财经大学	上海财经大学会计与财务研究院	1996	上海市国定路 777 号
上海财经大学	上海财经大学交叉科学研究院	2013	上海市国定路 777 号研究生院楼
上海财经大学	上海财经大学三农研究院	2017	上海市国定路 777 号
上海财经大学	上海财经大学上海发展研究院	2013	上海市国定路 777 号红瓦楼一楼
上海财经大学	上海财经大学上海国际金融中心研究院	2012	上海市武东路 100 号同德楼
上海财经大学	上海财经大学数据科学与统计研究院	2015	上海市国定路 777 号

上海财经大学	上海财经大学浙江学院	2008	浙江省金华市环城南路 99 号
上海财经大学	上海财经大学政府统计研究院	2017	上海市国定路 777 号
上海财经大学	上海财经大学中国公共财政研究院	2012	上海市杨浦区武川路 111 号凤凰楼 204 室
上海财经大学	上海财经大学中国经济思想发展研究院	2020	上海市杨浦区武川路 111 号上海财经大学中国经济思想发展研究院
上海财经大学	上海财经大学自由贸易区研究院	2013	上海市国定路 777 号红瓦楼一楼
上海财经大学	上海国际金融与经济研究院	2018	上海市杨浦区上海财经大学武东路校区上海国际金融与经济研究院
上海财经大学	上海国际组织与全球治理研究院	2017	上海市国定路 777 号
上海财经大学	上海市马克思主义理论研究院	2018	上海市国定路 777 号
上海财经大学	长三角与长江经济带发展研究院	2019	上海市杨浦区国定路 777 号红瓦楼
上海大学	上海大学宝山校区	1999	上海市宝山区上大路 99 号
上海大学	上海大学材料基因组工程研究院	2014	上海市宝山区上大路 99 号
上海大学	上海大学全球问题研究院	2016	上海市宝山区上大路 99 号
上海大学	上海大学人工智能研究院	2020	上海宝山区南陈路 333 号 10 号楼
上海大学	上海大学无人艇工程研究院	2010	上海市宝山区上大路 99 号
上海大学	上海大学转化医学研究院	2018	上海市宝山区上大路 99 号
上海大学	中瑞先进技术研究院	2021	上海市宝山区上大路 99 号
上海交通大学	上海交大平湖智能光电研究院	2019	浙江省平湖市新兴二路 988 号科创中心三号楼三楼
上海交通大学	上海交通大学密西根学院	2006	上海市闵行区东川路 800 号
上海交通大学	上海交通大学闵行校区	1896	上海市闵行区东川路 800 号
上海交通大学	上海交通大学深圳研究院	2000	深圳市南山区科技园南区虚拟大学园 B202 室
上海交通大学	上海交通大学四川研究院	2017	成都科学城天府菁蓉中心 A 区 10 号楼二楼
上海交通大学	上海交通大学中欧国际工商学院	1994	上海市浦东新区红枫路 699 号
上海交通大学	上海交通大学重庆研究院	2020	重庆市渝北区龙兴镇两江大道 598 号贵格两江总部城 A 区 2 栋
上海交通大学	医工交叉创新研究院	2019	上海市杨浦区军工路 516 号格致堂 407 室
上海外国语大学	上海外国语大学虹口校区	1949	上海市虹口区大连西路 550 号
上海外国语大学	上海外国语大学上海全球治理与区域国别研究院	2018	上海外国语大学松江校区文翔路 1550 号小别墅 23 号
上海外国语大学	上海外国语大学松江校区	2000	中国上海市文翔路 1550 号
上海外国语大学	上海外国语大学外语教材研究院	2019	上海市虹口区大连西路 558 号 611 室
上海外国语大学	上海外国语大学贤达经济人文学院	2004	虹口校区：上海市虹口区东体育会路 390 崇明校区：上海市崇明区东滩大道 999
上海外国语大学	上海外国语大学语料库研究院	2019	上海市松江区文翔路 1550 号第 5 教学楼
上海外国语大学	上海外国语大学语言研究院	2007	上海市大连西路 550 号 5 号楼 607 室
石河子大学	石河子大学	1949	新疆维吾尔自治区石河子市北四路 221 号
石河子大学	石河子大学科技学院	2002	新疆五家渠市石河子大学五家渠校区
石河子大学	石河子大学南疆研究院	2021	郑州市高新区科学大道 100 号
石河子大学	石河子大学商学院	2001	新疆五家渠市石河子大学五家渠校区
四川大学	四川大学华西医学中心	2000	四川省成都市人民南路三段十七号
四川大学	四川大学江安校区	2002	四川省成都市双流区西航港街道川大路二段 2 号
四川大学	四川大学锦城学院	2005	四川省成都市高新西区西源大道 1 号

四川大学	四川大学锦江学院	2006	四川·彭山·锦江大道一号
四川大学	四川大学青岛研究院	2016	青岛市即墨区鳌山卫街道蓝色硅谷核心区创业中心二期B座
四川大学	四川大学苏州研究院	2007	江苏苏州科教创新区东平街289号德胜楼三层四川大学苏州研究院
四川大学	四川大学望江校区	1896	四川省成都市武侯区一环路南一段24号
四川大学	四川大学中国藏学研究所	2000	四川省成都市望江路29号四川大学红瓦楼侧面
四川农业大学	四川农业大学	1906	四川省雅安市新康路46号
四川农业大学	四川农业大学新农村发展研究院	2012	四川省成都市温江区惠民路211号
苏州大学	苏州大学独墅湖校区	2004	中国江苏省苏州市吴中区仁爱路199号
苏州大学	苏州大学高等研究院	2017	苏州市十梓街1号
苏州大学	苏州大学高技术产业研究院	2010	苏州市十梓街1号
苏州大学	苏州大学能源与材料创新研究院	2017	苏州市姑苏区莫邪路688号
苏州大学	苏州大学人工智能研究院	2017	江苏省苏州市干将东路178号苏州大学北校区工科楼
苏州大学	苏州大学生物学研究院	2010	江苏省苏州工业园区仁爱路199号
苏州大学	苏州大学苏州知识产权研究院	2014	高新区学森路9号知识产权服务集聚区5幢4层
苏州大学	苏州大学唐仲英医学研究院	2013	江苏省苏州市苏州工业园区苏州大学独墅湖校区南区
苏州大学	苏州大学文正学院	1998	江苏省苏州市吴中区吴中大道1188号
苏州大学	苏州大学相城机器人与智能装备研究院	2015	苏州市相城区澄阳路116号 阳澄湖国际科技园2号楼202室
苏州大学	苏州大学阳澄湖校区	2012	苏州市十梓街1号
苏州大学	苏州大学艺术研究院	2013	江苏省苏州工业园区仁爱路199号
苏州大学	苏州大学应用技术学院	1997	苏州市昆山市周庄镇大学路1号
苏州大学	苏州大学转化医学研究院	2011	苏州市工业园区仁爱路199号苏州大学403号楼
太原理工大学	太原理工大学明向校区	2014	山西省晋中市榆次区大学街209号
太原理工大学	太原理工大学现代科技学院	2001	山西省太原市迎泽西大街新矿院路18号
太原理工大学	太原理工大学新型碳材料研究院	2019	山西省晋中市榆次区大学街209号太原理工大学
太原理工大学	太原理工大学迎西校区	1902	中国山西省太原市万柏林区迎泽西大街79号
天津大学	天津大学北洋园校区	2015	天津市津南区海河教育园雅观路135号
天津大学	天津大学仁爱学院	2006	天津市静海区团泊新城东区博学苑
天津大学	天津大学山东研究院	2010	淄博市鲁泰大道51号高分子材料创新园B座404室
天津大学	天津大学卫津路校区	1895	天津市南开区卫津路92号
天津医科大学	天津医科大学	1951	天津市和平区气象台路22号
天津医科大学	天津医科大学临床医学院	2004	天津市滨海新区大港学苑路167号
天津医科大学	天津医科大学医学工程与转化医学研究院	2017	天津市南开区卫津路92号天津大学医学工程与转化医学研究院办公楼
同济大学	东莞同济大学研究院	2014	广东省东莞市松山湖国际创新创业社区D3栋
同济大学	同济大学沪北校区	2000	上海市中山北路727号(共和新路口)
同济大学	同济大学沪西校区	2004	上海市普陀区真南路500号
同济大学	同济大学嘉定校区	2001	上海市嘉定区曹安公路4800号
同济大学	同济大学四平路校区	1907	上海市杨浦区四平路1239号
同济大学	同济大学同科学院	2006	中山北路727号同济大学沪北校区

同济大学	同济大学中德学院	1998	上海市赤峰路 50 号中德大楼
武汉大学	武汉大学	1893	湖北省武汉市武昌区珞珈山街道八一路 299 号
武汉大学	武汉大学东湖分校	2000	湖北省武汉市江夏区文化大道 301 号
武汉大学	武汉大学广东（深圳）研究院	2000	深圳市南山区科技园南区科苑南路武汉大学深圳产学研大楼 A302
武汉大学	武汉大学珞珈学院	2006	湖北省武汉市东湖新技术开发区中华科技产业园玉屏大道 9 号
武汉大学	武汉大学西南研究院	2015	成都市双流区星空路二段佳兆业现代城 31 栋 5 楼
武汉理工大学	武汉理工大学	1898	湖北省武汉市珞狮路 122 号
武汉理工大学	武汉理工大学华夏学院	2003	湖北省武汉东湖新技术开发区关山大道 589 号
武汉理工大学	武汉理工大学韶关研究院	2020	广东省韶关市曲江区马坝镇武汉理工大学韶关研究院
武汉理工大学	武汉理工大学绍兴高等研究院	2018	浙江省绍兴市上虞区曹娥街道浙大网新科技园 A1 楼 5F
武汉理工大学	武汉理工大学咸宁研究院	2020	湖北省咸宁市咸安区咸宁大道 118 号咸宁职业技术学院；湖北省咸宁市咸宁高新开发区旗鼓大道 15 号金融港
武汉理工大学	中山市武汉理工大学先进工程技术研究院	2011	中山市火炬开发区祥兴路 6 号数贸大厦 1 栋 3 楼
西安电子科技大学	西安电子科技大学北校区	1931	陕西省西安市雁塔区太白南路 2 号
西安电子科技大学	西安电子科技大学广州研究院	2020	广东省广州市黄埔区中新知识城海丝中心 B5、B6、B7 栋
西安电子科技大学	西安电子科技大学杭州研究院	2020	浙江省杭州市萧山区萧山经济技术开发区钱农东路 8 号
西安电子科技大学	西安电子科技大学南校区	2004	西安市长安区西沔路 266 号
西安电子科技大学	西安电子科技大学宁波信息技术研究院	2012	宁波市大学科技园创 E 慧谷
西安电子科技大学	西安电子科技大学青岛计算技术研究院	2019	山东省青岛市城阳区春阳路 88 号天安数码城 28,29 号楼
西安电子科技大学	西安电子科技大学深圳研究院	2000	深圳市南山区高新南四道虚拟大学园 A215
西安电子科技大学	西安电子科技大学芜湖研究院	2018	芜湖市弋江区芜湖科技产业园
西安电子科技大学	西安电子科技大学长安学院	2004	西安电子科技大学南校区丁香 15 号楼一层 103 室（老校区）陕西省富平县职教园区（新校区）
西安交通大学	广东西安交通大学研究院	2010	陕西省西安市咸宁西路 28 号主教学区东南门内东二舍西侧
西安交通大学	西安交通大学城市学院	2004	陕西省西安市未央区西安经济技术开发区草滩生态产业园尚稷路 8715 号
西安交通大学	西安交通大学青岛研究院	2013	中国·胶州国家级经济技术开发区汇英街 2 号
西安交通大学	西安交通大学曲江校区	2013	陕西省西安市雁塔区雁翔路 99 号
西安交通大学	西安交通大学深圳研究院	2000	深圳市南山区高新南四道 19 号虚拟大学园 A206
西安交通大学	西安交通大学苏州研究院	2004	苏州工业园区仁爱路 99 号 C 幢 110 室
西安交通大学	西安交通大学兴庆校区	1896	西安市碑林区咸宁西路 28 号
西安交通大学	西安交通大学雁塔校区	2000	陕西省西安市雁塔西路 76 号
西安交通大学	浙江西安交通大学研究院	2011	杭州市萧山区文明路 328 号江宁大厦 A 座五楼
西北大学	陕西省宏观经济研究院	2016	中国·陕西省西安市长安区郭杜教育科技产业区学府大道 1 号
西北大学	西北大学关学研究院	2018	陕西省西安市碑林区太白北路 229 号

西北大学	西北大学科学史高等研究院	2016	西安市长安区西北大学西学楼2层
西北大学	西北大学南校区	2005	西安市长安区郭杜镇学府大道1号
西北大学	西北大学丝绸之路研究院	2013	西安市太白北路229号
西北大学	西北大学现代学院	2003	陕西省西安市长安区滦镇科教园陈北路1号
西北大学	西北大学玄奘研究院	2015	陕西省西安市长安区学府大道1号
西北大学	西北大学延安精神与党的建设研究院	2016	西安市长安区学府大道1号西北大学延安精神与党的建设研究院
西北大学	西北大学延安精神与党的建设研究院	2016	西安市长安区学府大道1号西北大学延安精神与党的建设研究院
西北工业大学	北工业大学青岛研究院	2017	陕西省西安市长安区西北工业大学长安校区895号
西北工业大学	西北工业大学北京研究院	2019	北京市海淀区中关村南大街31号神舟大厦15层
西北工业大学	西北工业大学明德学院	1999	陕西省西安市长安区滦镇街道西留堡村
西北工业大学	西北工业大学深圳研究院	1999	深圳市南山区高新南九道45号西北工业大学深圳三航科技大厦25层
西北工业大学	西北工业大学友谊校区	1938	陕西省西安市碑林区友谊西路127号
西北农林科技大学	上合现代农业发展研究院	2021	陕西杨凌
西北农林科技大学	西北农林科技大学	1934	陕西省咸阳市杨凌示范区邠城路3号
西南财经大学	西南财经大学北京研究院	2013	北京市西城区华远北街2号通港大厦608
西南财经大学	西南财经大学金融研究院	2010	四川省成都市青羊区光华村街55号西南财经大学35栋金融研究院
西南财经大学	西南财经大学经济与管理研究院	2006	成都市温江区柳台大道555号格致楼12楼
西南财经大学	西南财经大学柳林校区	2004	四川省成都市温江区柳台大道东段555号
西南财经大学	西南财经大学社会发展研究院	2017	成都温江柳台大道555号通博楼
西南财经大学	西南财经大学天府学院	2006	绵阳校区：四川省绵阳市科创园园区园兴西街2号 成都校区：四川省成都市成华区龙潭总部经济城内 德阳校区：四川省德阳市罗江区大学北路99号
西南财经大学	西南财经大学中国西部经济研究院	2000	四川省成都市温江区柳台大道555号 西南财经大学格致楼1123
西南大学	西南大学	1906	重庆市北碚区天生路2号
西南大学	西南大学洁净能源与先进材料研究院	2011	重庆市北碚区天生路2号（原五一所内，西南大学第三运动场旁）
西南大学	西南大学农业科学研究院	2017	重庆市北碚区天生路2号
西南大学	西南大学统筹城乡发展研究院	2009	重庆市北碚区天生路2号
西南大学	西南大学新农村发展研究院	2012	西南大学中国乡村建设学院乡村建设研究
西南大学	西南大学医学研究院	2018	重庆市北碚区天生路2号西南大学
西南交通大学	西南交通大学国际老龄科学研究院	2015	中国成都市高新西区西南交通大学犀浦校区综合楼
西南交通大学	西南交通大学前沿科学技术研究院	2018	西南交通大学九里校区一号综合楼四楼
西南交通大学	西南交通大学人工智能研究院	2018	四川省成都市郫都区犀安路999号
西南交通大学	西南交通大学希望学院	2009	四川省成都市金堂县学府大道558号
西南交通大学	西南交通大学犀浦校区	2002	四川省成都市郫都区犀安路999号
新疆大学	新疆大学博达校区	2021	乌鲁木齐市水磨沟区华瑞街777号
新疆大学	新疆大学红湖校区	1924	新疆维吾尔自治区乌鲁木齐市天山区胜利路666号
新疆大学	新疆大学科学技术学院	2002	新疆维吾尔自治区阿克苏市学府西路1号

延边大学	延边大学珲春校区	2017	吉林省珲春市站前大街 5588 号
延边大学	延边大学延吉校区	1949	吉林省延边朝鲜族自治州延吉市公园路 977 号
云南大学	云南大学呈贡校区	2010	中国云南省昆明市呈贡区庆来西路
云南大学	云南大学滇池学院	2001	云南省昆明滇池国家旅游度假区红塔东路 2 号
云南大学	云南大学发展研究院	1998	昆明市一二一大街 182 号云南大学科学馆四楼
云南大学	云南大学高等教育研究院	2002	云南大学文津楼 501 室
云南大学	云南大学古生物研究院	2001	云南大学（呈贡校区）礼贤楼
云南大学	云南大学国际关系研究院	2002	昆明市五华区翠湖北路 2 号云南大学映秋院三楼
云南大学	云南大学国际河流与生态安全研究院	2012	云南省昆明市呈贡区大学城云学路西二门综合楼
云南大学	云南大学缅甸研究院	2015	昆明市翠湖北路 2 号
云南大学	云南大学民族政治研究院	2013	昆明市翠湖北路 2 号
云南大学	云南大学生物医药研究院	2019	云南大学呈贡校区实训大楼 3 号楼
云南大学	云南大学文化发展研究院	2003	北京朝阳区定福庄东街 1 号中国传媒大学 39 号楼
云南大学	云南大学资源植物研究院	2019	昆明市呈贡区大学城云南大学农学院
长安大学	长安大学科学研究院	2019	西安市朱宏路北段长安大学渭水校区北辰楼 8 楼
长安大学	长安大学渭水校区	2003	西安市朱宏路北段 1 号
长安大学	长安大学兴华学院	2006	陕西省西安市富鱼路 81 号
浙江大学	海南浙江大学研究院	2019	海南省三亚市崖州湾科技城用友产业园 11 号楼
浙江大学	浙江大学滨江研究院	2020	浙江省杭州市滨江区东信大道 66 号东方通信科技园二号楼 3 楼
浙江大学	浙江大学常州工业技术研究院	2013	常州市新北区华山中路 9 号
浙江大学	浙江大学城市学院	1999	南校区：浙江省杭州市拱墅区湖州街 51 号（310015） 北校区：浙江省杭州市拱墅区湖州街 50 号（310015）
浙江大学	浙江大学海宁国际校区	2016	浙江省海宁市海州东路 718 号
浙江大学	浙江大学湖州研究院	2021	湖州市西塞山路 819 号南太湖新区科技创新综合体 B1、B2 幢 2-3 层
浙江大学	浙江大学金华研究院	2021	浙江省金华市金义新区金华科技城浙大网新孵化园 A 区
浙江大学	浙江大学宁波理工学院	2001	浙江省宁波市鄞州区首南街道钱湖南路 1 号
浙江大学	浙江大学宁波校区	2018	浙江省宁波市鄞州区高教园区钱湖南路 1 号
浙江大学	浙江大学衢州研究院	2018	浙江省衢州市柯城区浙大路 99 号
浙江大学	浙江大学山东（临沂）现代农业研究院	2019	山东省临沂市河东区中科创新园 7-10 楼
浙江大学	浙江大学山东工业技术研究院	2016	山东省枣庄市高新区互联网小镇 15 号楼
浙江大学	浙江大学深圳研究院	2002	深圳市南山区科技园南区深圳虚拟大学园 A310 室，A609 室，A612 室
浙江大学	浙江大学苏州工业技术研究院	2011	江苏省苏州市高新区科灵路 78 号
浙江大学	浙江大学台州研究院	2005	浙江省台州市市府大道西段 618 号
浙江大学	浙江大学温州研究院	2019	温州市瓯海区凤南路 26 号
浙江大学	浙江大学玉泉校区	1956	浙江省杭州市西湖区浙大路 38 号
浙江大学	浙江大学中原研究院	2019	河南省郑州市高新技术产业开发区长椿路 6 号西美大厦 B 座
浙江大学	浙江大学舟山校区	2012	浙江省舟山市定海区浙大路 1 号
浙江大学	浙江大学紫金港校区	2001	浙江省杭州市西湖区余杭塘路 866 号

郑州大学	河南先进技术研究院	2017	河南省郑州市金水区文化路 97 号郑州大学北校区河南先进技术研究院
郑州大学	郑州大学产业技术研究院	2015	郑州市高新区长椿路 11 号 1 号孵化楼 8 层
郑州大学	郑州大学环境科学研究院	2005	河南省郑州市高新技术开发区科学大道 100 号
郑州大学	郑州大学洛阳校区	1956	河南省郑州市科学大道 100 号
郑州大学	郑州大学洛阳校区	2021	河南省洛阳市，洛阳机场路以南、周山大道以西，毗邻洛阳北郊机场（过渡校区）
郑州大学	郑州大学洛阳研究院	2018	河南省洛阳市，洛阳机场路以南、周山大道以西，毗邻洛阳北郊机场（过渡校区）
郑州大学	郑州大学马克思主义研究院	2021	郑州高新区科学大道 100 号
郑州大学	郑州大学西亚斯学院	1998	河南省郑州市新郑市人民路 168 号
郑州大学	郑州大学许昌研究院	2016	河南省许昌市建安区
郑州大学	郑州升达经贸管理学院	1993	河南省新郑市龙湖镇文昌路 1 号
郑州大学	中原网络安全研究院	2021	郑州市文化路 97 号
中国传媒大学	中国传媒大学	1954	北京市朝阳区定福庄东街 1 号
中国传媒大学	中国传媒大学擎雅品牌研究院	2021	北京市朝阳区定福庄东街 1 号
中国传媒大学	中国传媒大学国际创作研究院	2020	北京市朝阳区定福庄东街 1 号 32 号楼 302 室
中国传媒大学	中国传媒大学国家广告研究院	2011	北京市朝阳区定福庄东街 1 号中国传媒大学 45 号楼
中国传媒大学	中国传媒大学国家治理研究院	2019	北京市朝阳区定福庄东街 1 号中国传媒大学国重大楼 9 层
中国传媒大学	中国传媒大学互联网信息研究院	2013	北京市朝阳区定福庄东街 1 号
中国传媒大学	中国传媒大学媒介与公共事务研究院	2013	北京市朝阳区定福庄东街 1 号
中国传媒大学	中国传媒大学美术创作研究院	2021	昌平区平西王府
中国传媒大学	中国传媒大学南广学院	2004	江苏省南京市江宁区弘景大道 3666 号
中国传媒大学	中国传媒大学脑科学与智能媒体研究院	2013	北京市朝阳区定福庄东街 1 号中国传媒大学 42 号楼 2 层
中国传媒大学	中国传媒大学数字经济创新研究院	2014	北京市朝阳区定福庄东街 1 号 32 号楼 302 室
中国传媒大学	中国传媒大学文化发展研究院	2006	北京朝阳区定福庄东街 1 号中国传媒大学 39 号楼
中国传媒大学	中国传媒大学无障碍信息传播研究院	2020	北京市朝阳区定福庄东街 1 号
中国传媒大学	中国传媒大学雄安新区发展研究院	2017	朝阳区定福庄东街 1 号中国传媒大学 2 号楼 1207
中国地质大学（北京）	中国地质大学（北京）科学研究院	2011	北京市海淀区学院路 29 号
中国地质大学（北京）	中国地质大学（北京）自然文化研究院	2020	北京市海淀区学院路 29 号
中国地质大学（北京）	中国地质大学（北京）自然资源战略发展研究院	2020	北京市海淀区学院路 29 号中国地质大学（北京）综合办公楼 710 室
中国地质大学（武汉）	中国地质大学（武汉）地质调查研究院	2020	湖北省武汉市洪山区鲁磨路 388 号
中国地质大学（武汉）	中国地质大学（武汉）南望山校区	1952	湖北省武汉市洪山区鲁磨路 388 号
中国地质大学（武汉）	中国地质大学（武汉）未来城校区	2011	湖北省武汉东湖新技术开发区锦程街 68 号

中国地质大学（武汉）	中国地质大学（武汉）浙江研究院	2010	湖北省武汉市洪山区鲁磨路 388 号
中国海洋大学	中国海洋大学青岛校区	2016	山东省青岛市黄岛区古镇口军民融合创新示范区三沙路 1299 号
中国海洋大学	中国海洋大学崂山校区	1924	山东省青岛市松岭路 238 号
中国海洋大学	中国海洋大学青岛学院	2005	山东省青岛胶州市福州南路 236 号
中国海洋大学	中国海洋大学三亚海洋研究院	2020	海南省三亚市崖州湾科技城用友产业园 1 号楼 7 层
中国科学技术大学	中国科学技术大学	1958	安徽省合肥市金寨路 96 号
中国科学技术大学	中国科学技术大学北京研究院	2017	北京市石景山区 19 号甲（中国科学技术大学北京教学基地综合楼）1-3 层
中国科学技术大学	中国科学技术大学上海研究院	2004	上海市浦东新区康桥镇秀浦路 99 号
中国科学技术大学	中国科学技术大学苏州高等研究院	2003	苏州工业园区独墅湖科教创新区仁爱路 188 号（西区），仁爱路 166 号（东区）
中国科学院	中国科学院大学	1949	北京市三里河路 52 号
中国科学院	中国科学院大学雁栖湖校区	2013	北京市石景山区玉泉路（甲）19 号
中国科学院	中国科学院科技战略咨询研究院	2015	北京市海淀区中关村北一条 15 号
中国科学院	中国科学院数学与系统科学研究院	1998	北京市海淀区中关村东路 55 号
中国科学院	中国科学院西北生态环境资源研究院	2016	甘肃省兰州市东岗西路 320 号
中国矿业大学	中国矿业大学南湖校区	2004	江苏省徐州市铜山区大学路 1 号
中国矿业大学	中国矿业大学人工智能研究院	2020	江苏省徐州市大学路 1 号中国矿业大学南湖校区
中国矿业大学	中国矿业大学深圳研究院	2020	广东省深圳市南山区高新南四道 19 号深圳虚拟大学园
中国矿业大学	中国矿业大学碳中和研究院	2009	江苏省徐州市中国矿业大学文昌校区教三楼
中国矿业大学	中国矿业大学徐海学院	1999	江苏省徐州市金山东路 1 号中国矿业大学文昌校区
中国农业大学	中国农业大学东校区	1905	北京市海淀区清华东路 17 号
中国农业大学	中国农业大学西校区	1905	北京市海淀区圆明园西路 2 号
中国农业大学	中国农业大学烟台研究院	2007	山东省烟台市高新区滨海中路 2006 号
中国农业大学	中国农业大学有机循环研究院（苏州）	2018	江苏省苏州市吴中区长蠡路 366 号
中国人民大学	中国人民大学	1937	北京市海淀区中关村大街 59 号
中国人民大学	中国人民大学深圳研究院	2002	深圳市南山区高新南四道 19 号虚拟大学园 A505 室
中国人民大学	中国人民大学苏州校区	2012	江苏省苏州工业园区仁爱路 158 号
中国人民大学	中国人民大学通州校区	2023	北京市通州区潞城镇
中国人民大学	中国人民大学重阳金融研究院	2013	北京市海淀区中关村大街 59 号文化大厦 6 层
中国社会科学院	中国非洲研究院	2018	中国北京建国门内大街 5 号
中国社会科学院	中国社会科学院评价研究院	2017	中国北京建国门内大街 5 号
中国社会科学院	中国社会科学院马克思主义研究院	2005	北京市房山区长于大街 11 号
中国社会科学院	中国社会科学院社会发展战略研究院	2011	中国北京建国门内大街 5 号
中国社会科学院	中国社会科学院信息情报研究院	2011	中国北京建国门内大街 5 号
中国社会科学院	中国社会科学院亚太与全球战略研究院	2011	中国北京建国门内大街 5 号
中国石油大学（北京）	中国石油大学（北京）	1953	北京市昌平区府学路 18 号
中国石油大学（北京）	中国石油大学（北京）非常规油气科学技术研究院	2011	北京市昌平区府学路 18 号

中国石油大学（北京）	中国石油大学（北京）克拉玛依校区	2015	北京市丰台区张家路口 121 号博学楼东南角一层就业指导中心
中国石油大学（华东）	中国石油大学（华东）东营校区	2022	山东省东营市东营区北一路 739 号
中国石油大学（华东）	中国石油大学（华东）古镇口校区	2019	山东省青岛市黄岛区三沙路
中国石油大学（华东）	中国石油大学（华东）科学技术研究院	2009	山东省东营市东营区北一路 739 号
中国石油大学（华东）	中国石油大学（华东）青岛唐岛湾校区	2005	青岛市黄岛区长江西路 66 号
中国石油大学（华东）	中国石油大学（华东）新能源研究院	2018	山东省青岛市黄岛区长江西路 66 号特种实验楼 C 区
中国药科大学	中国药科大学（杭州）创新药物研究院	2019	杭州市钱塘新区下沙街道福城路 291 号医药港小镇 4-402
中国药科大学	中国药科大学江宁校区	2012	江苏省南京市江宁区龙眠大道 639 号
中国药科大学	中国药科大学药物科学研究院	2010	江苏省南京市童家巷 24 号
中国药科大学	重庆中国药科大学创新研究院	2020	重庆市渝北区龙兴镇际华园东路 77 号
中国政法大学	中国政法大学	1952	北京市海淀区西土城路 25 号
中国政法大学	中国政法大学比较法学研究院	2009	北京市海淀区西土城路 25 号
中国政法大学	中国政法大学法律史学研究院	2002	北京市海淀区西土城路 25 号
中国政法大学	中国政法大学法与经济学研究院	2005	北京市海淀区西土城路 25 号
中国政法大学	中国政法大学法治政府研究院	2005	北京市海淀区西土城路中国政法大学 3 号楼
中国政法大学	中国政法大学人权研究院	2011	海淀区西土城路 25 号中国政法大学
中国政法大学	中国政法大学诉讼法学研究院	1999	北京市海淀区西土城路 25 号
中南财经政法大学	中南财经政法大学	1948	湖北省武汉市东湖新技术开发区南湖大道 182 号
中南财经政法大学	中南财经政法大学法律文化研究院	2006	湖北省武汉市东湖新技术开发区南湖大道 182 号
中南财经政法大学	中南财经政法大学马克思主义发展研究院	2007	湖北省武汉市东湖新技术开发区南湖大道 182 号
中南财经政法大学	中南财经政法大学武汉学院	2003	湖北省武汉市江夏区黄家湖大道 333 号
中南大学	中南大学	2000	湖南省长沙市岳麓区麓山南路 932 号
中山大学	南方学院	2006	广东省广州市从化区温泉镇温泉大道 882 号
中山大学	新华学院	2005	广州校区：广州市天河区龙洞华美路 19 号 东莞校区：东莞市麻涌镇沿江西路 248 号
中山大学	中山大学北校区	2001	广东省广州市越秀区中山二路 74 号
中山大学	中山大学东校区	2004	中国广东省广州市番禺区大学城外环东路 132 号
中山大学	中山大学南校区	1924	广东省广州市海珠区新港西路 135 号
中山大学	中山大学深圳校区	2015	中国广东省深圳市光明区新湖街道公常路 66 号
中山大学	中山大学珠海校区	2000	珠海市香洲区唐家湾镇
中央财经大学	中央财经大学绿色金融国际研究院	2016	北京市海淀区学院南路 39 号
中央财经大学	中央财经大学区块链技术与应用研究院	2020	北京市海淀区学院南路 39 号
中央财经大学	中央财经大学沙河校区	2009	北京市昌平区沙河高教园区
中央财经大学	中央财经大学文化经济研究院	2006	北京市海淀区学院南路 39 号
中央财经大学	中央财经大学中国互联网经济研究院	2013	北京市海淀区学院南路 39 号中央财经大学

中央财经大学	中央财经大学中国金融发展研究院	2006	北京市海淀区学院南路 39 号
中央财经大学	中央财经大学中国精算研究院	1993	北京昌平区沙河高教园
中央民族大学	中央民族大学藏学研究院	2000	北京市海淀区中关村南大街 27 号
重庆大学	重庆大学	1929	重庆市沙坪坝区沙正街 174 号
重庆大学	重庆大学城市科技学院	2005	永川校区：重庆市永川区光彩大道 368 号 巴南校区：重庆市巴南区高职城（在建）
重庆大学	重庆大学虎溪校区	2005	重庆市高新区大学城南路 55 号

Table OA.15: Baseline Regressions Estimated within Industries.

We estimate baseline regressions of Tables 2 and 3 across 38 industrial industries covered in the NBS dataset. The dependent variables are *New Product Sales* in year $t+1$ in Panel A, *Product-Oriented PatCount* in year $t+1$ in Panel B, and *Product-Oriented PatCite* in year $t+1$ in Panel C, respectively. As the independent variables, *Patent-Based IUC* and *Paper-Based IUC* are measured in *Dummy*. We also control for innovation-related variables such as *Patent Portfolio Size* and *R&D Intensity*. We further control for firm characteristics such as *Total Assets* (in billion RMB), *Age*, *Cash Ratio*, *Capital Expenditure Intensity*, *Profitability Ratio*, *Sales Growth*, *Export Ratio*, *Leverage Ratio*, *Labor Ratio*, *Wage per Employee*, *Subsidy Ratio*, as well as firm fixed effects, and province-year fixed effects. All control variables are defined in Table 1. Sample period of t is from 1998 to 2013. The outcome variable and all control variables are winsorized at their 1st and 99th percentiles. Numbers in parentheses denote standard errors clustered by firms. ***, **, * indicate significance levels of 1%, 5%, and 10%, respectively.

Industry \ Coefficients of	Panel A: Dept Var = New Product Sales		Panel B: Dept Var = Product-Oriented PatCount		Panel C: Dept Var = Product-Oriented PatCite	
	Patent-Based IUC	Paper-Based IUC	Patent-Based IUC	Paper-Based IUC	Patent-Based IUC	Paper-Based IUC
Mining: Coal (06)	0.0646	0.0725	0.4486***	0.0809*	0.0276	0.0036
Mining: Petroleum (07)	0.3782***	0.0664	0.3160**	0.1732	0.0286	0.0483
Mining: Ferrous Metals (08)	0.0000	0.0000	0.3711	0.0534	0.0118	0.0618*
Mining: Non-Ferrous Metals (09)	0.0112	0.5701***	0.0472	0.0586	0.0011	0.0142
Mining: Non-Metallic Minerals (10)	0.5799***	0.3271***	0.3139***	0.1276	0.1066***	0.0648***
Manufacturing: Agricultural and Agrifoods (13)	0.1898***	0.1447***	0.0166	0.0115	0.0067	0.0067
Manufacturing: Food Products (14)	0.1856**	0.0088	0.0721	0.0725**	0.0303**	0.0283***
Manufacturing: Beverages (15)	0.2816**	0.2352***	0.1707***	0.0220	0.0318**	0.0055
Manufacturing: Tabacco (16)	0.4608*	0.1948	0.5617***	0.0578	0.0066	0.0282
Manufacturing: Textile (17)	0.0690	0.1762***	0.0716	0.1579***	0.0041	0.0019
Manufacturing: Clothing (18)	0.1422	0.1306	0.1916*	0.1100	0.0143	0.0182
Manufacturing: Leather (19)	0.1449	0.2368	0.0192	0.3461***	0.0222	0.0403**
Manufacturing: Wood (20)	0.0217	0.0696	0.1536	0.0795	0.0088	0.0455*
Manufacturing: Furniture (21)	0.2100	0.8711***	0.1521	0.5199***	0.0334	0.0680***
Manufacturing: Paper (22)	0.7999***	0.0364	0.1858	0.0646	0.0310	0.0106
Manufacturing: Print (23)	0.0688	0.1288	0.3158***	0.0852	0.0141	0.0054
Manufacturing: Recreational Supplies (24)	0.0696	0.0039	0.1239	0.8008***	0.0353**	0.1581***
Manufacturing: Energy (25)	0.154	0.1267	0.0256	0.1379**	0.0022	0.0010
Manufacturing: Chemicals (26)	0.1281***	0.1409***	0.1047***	0.0298**	0.0094*	0.001
Manufacturing: Pharmaceuticals (27)	0.2149***	0.0192	0.1066***	0.0072	0.0157**	0.0004
Manufacturing: Chemical Fibers (28)	0.3815**	0.3041**	0.0423	0.0694	0.0112	0.0043
Manufacturing: Plastics (29)	0.0580	0.0045	0.3708***	0.0615	0.0636**	0.0131
Manufacturing: Building Materials (30)	0.2046***	0.1390***	0.4010***	0.0331	0.0600***	0.0068
Manufacturing: Steel (31)	0.1101**	0.0723**	0.0399	0.0106	0.0166	0.0106*
Manufacturing: Non-Ferrous Metals (32)	0.2313***	0.3544***	0.1619***	0.0147	0.0175	0.0157*
Manufacturing: Metalware (33)	0.4100***	0.2866***	0.1709***	0.0887**	0.0433***	0.0113
Manufacturing: General Equipment (34)	0.4878***	0.1138***	0.2615***	0.0224	0.0346***	0.0088
Manufacturing: Special Equipment (35)	0.0934***	0.0652***	0.0761**	0.0572***	0.0116*	0.0066*
Manufacturing: Automobiles (36)	0.1301***	0.0143	0.0828**	0.1496***	0.0031	0.0199***
Manufacturing: Trains and Aeroplanes (37)	0.1882***	0.1846***	0.2939***	0.1237***	0.0338***	0.0101**
Manufacturing: Computers (39)	0.1061**	0.0337	0.1128**	0.0496	0.0103	0.0093
Manufacturing: Instruments and Apparatuses (40)	0.1001*	0.0498*	0.0898**	0.1036***	0.0005	0.0051
Manufacturing: Daily Necessities (41)	0.0604	0.0841**	0.1378***	0.1684***	0.0088	0.0201***
Manufacturing: Recycling (42)	0.0795	0.0603	0.0448	0.1485***	0.0146	0.0116
Manufacturing: Equipment Repairing (43)	0.1046	0.0463	0.0214	0.0364	0.0723***	0.0257*
Production and Supply: Electricity (44)	0.0601**	0.0277*	0.5209***	0.028	0.0551***	0.0025
Production and Supply: Gas (45)	0.0532	0.0000	0.0437	0.1856**	0.0308	0.0036
Production and Supply: Water (46)	0.0301	0.0116	0.0119	0.0142	0.014	0.0195**

Table OA.16: Effects of Granted IUC Patents vs. Unsuccessful IUC Patent Applications.

We execute pooled regressions to estimate the association of number of granted IUC patents and unsuccessful IUC Patent Applications on a firm's future performance of technology commercialization. Specifically, we regress the dependent variables, *New Product Sales* in year $t+1$ in a natural logarithm form in Panel A, *Product-Oriented PatCount* in year $t+1$ in a natural logarithm form in Panel B, and *Product-Oriented PatCite* in year $t+1$ in a natural logarithm form in Panel C on *Successful and Failed IUC Patent Applications*, *Granted IUC Patents*, and *Unsuccessful IUC Patent Applications* as independent variables in year $t-4$ to t . As the independent variables, *Granted IUC Patents* denotes the number of patents applied by both a university and the focal firm that are later successfully granted. *Unsuccessful IUC Patent Applications* denotes the number of patents applied by both a university and the focal firm that are never granted. *Successful and Failed IUC Patent Applications* is the sum of both *Granted IUC Patents* and *Unsuccessful IUC Patent Applications*. We control for *Total Sales* (in billion RMB). We also control for innovation-related variables such as *Patent Portfolio Size* and *R&D Intensity*. We further control for firm characteristics such as *Total Assets* (in billion RMB), *Age*, *Cash Ratio*, *Capital Expenditure Intensity*, *Profitability Ratio*, *Sales Growth*, *Export Ratio*, *Leverage Ratio*, *Labor Ratio*, *Wage per Employee*, *Subsidy Ratio*, as well as firm fixed effects, province-year fixed effects, and industry-year fixed effects. The outcome variable and all control variables are winsorized at their 1st and 99th percentiles. Numbers in parentheses denote standard errors clustered by firms. ***, **, * indicate significance levels of 1%, 5%, and 10%, respectively.

Panel A: Dept Var = New Product Sales				
	Panel A.1		Panel A.2	
	(1)	(2)	(1)	(2)
Successful and Failed IUC Patent Applications	0.0573*** (0.0183)	0.0547*** (0.0182)		
Granted IUC Patents			0.0532** (0.0219)	0.0514** (0.0218)
Unsuccessful IUC Patent Applications			0.0046 (0.0125)	0.0035 (0.0124)
#Obs	784,025	784,025	784,025	784,025
#Firms	92,521	92,521	92,521	92,521
R-squared	0.8280	0.8283	0.8280	0.8283
Total Sales as a Control	YES	YES	YES	YES
Innovation-Related Controls	YES	YES	YES	YES
Firm Characteristics Controls	NO	YES	NO	YES
Firm FE	YES	YES	YES	YES
Province-Year FE	YES	YES	YES	YES
Industry-Year FE	YES	YES	YES	YES
Panel B: Dept Var = Product-Oriented PatCount				
	Panel B.1		Panel B.2	
	(1)	(2)	(1)	(2)
Successful and Failed IUC Patent Applications	0.1212*** (0.0148)	0.1156*** (0.0148)		
Granted IUC Patents			0.1025*** (0.0177)	0.0980*** (0.0176)
Unsuccessful IUC Patent Applications			0.0279*** (0.0106)	0.0272*** (0.0103)
#Obs	784,025	784,025	784,025	784,025
#Firms	92,521	92,521	92,521	92,521
R-squared	0.4403	0.4442	0.4402	0.4442
Total Sales as a Control	YES	YES	YES	YES
Innovation-Related Controls	YES	YES	YES	YES
Firm Characteristics Controls	NO	YES	NO	YES
Firm FE	YES	YES	YES	YES
Province-Year FE	YES	YES	YES	YES
Industry-Year FE	YES	YES	YES	YES
Panel C: Dept Var = Product-Oriented PatCite				
	Panel C.1		Panel C.2	
	(1)	(2)	(1)	(2)
Successful and Failed IUC Patent Applications	0.0107*** (0.0028)	0.0102*** (0.0028)		
Granted IUC Patents			0.0107*** (0.0033)	0.0104*** (0.0033)
Unsuccessful IUC Patent Applications			0.0001 (0.0011)	0.0000 (0.0011)
#Obs	784,025	784,025	784,025	784,025
#Firms	92,521	92,521	92,521	92,521
R-squared	0.3014	0.3026	0.3013	0.3026
Total Sales as a Control	YES	YES	YES	YES
Innovation-Related Controls	YES	YES	YES	YES
Firm Characteristics Controls	NO	YES	NO	YES
Firm FE	YES	YES	YES	YES
Province-Year FE	YES	YES	YES	YES
Industry-Year FE	YES	YES	YES	YES